



SuperStack® 3

Switch 4900 Series

Getting Started Guide

Switch 4900 (3C17700)
Switch 4900 SX (3C17702)
Switch 4924 (3C17701)
Switch 4950 (3C17706)

<http://www.3com.com/>

Part No. DUA1770-0AAA04
Published August 2002



3Com Corporation
5400 Bayfront Plaza
Santa Clara, California
95052-8145

Copyright © 2002, 3Com Technologies. All rights reserved. No part of this documentation may be reproduced in any form or by any means or used to make any derivative work (such as translation, transformation, or adaptation) without written permission from 3Com Technologies.

3Com Technologies reserves the right to revise this documentation and to make changes in content from time to time without obligation on the part of 3Com Technologies to provide notification of such revision or change.

3Com Technologies provides this documentation without warranty, term, or condition of any kind, either implied or expressed, including, but not limited to, the implied warranties, terms or conditions of merchantability, satisfactory quality, and fitness for a particular purpose. 3Com may make improvements or changes in the product(s) and/or the program(s) described in this documentation at any time.

If there is any software on removable media described in this documentation, it is furnished under a license agreement included with the product as a separate document, in the hard copy documentation, or on the removable media in a directory file named LICENSE.TXT or !LICENSE.TXT. If you are unable to locate a copy, please contact 3Com and a copy will be provided to you.

UNITED STATES GOVERNMENT LEGEND

If you are a United States government agency, then this documentation and the software described herein are provided to you subject to the following:

All technical data and computer software are commercial in nature and developed solely at private expense. Software is delivered as "Commercial Computer Software" as defined in DFARS 252.227-7014 (June 1995) or as a "commercial item" as defined in FAR 2.101(a) and as such is provided with only such rights as are provided in 3Com's standard commercial license for the Software. Technical data is provided with limited rights only as provided in DFAR 252.227-7015 (Nov 1995) or FAR 52.227-14 (June 1987), whichever is applicable. You agree not to remove or deface any portion of any legend provided on any licensed program or documentation contained in, or delivered to you in conjunction with, this User Guide.

Unless otherwise indicated, 3Com registered trademarks are registered in the United States and may or may not be registered in other countries.

3Com, the 3Com logo, and SuperStack are registered trademarks of 3Com Corporation.

IEEE and 802 are registered trademarks of the Institute of Electrical and Electronics Engineers, Inc.

Intel and Pentium are registered trademarks of Intel Corporation. Microsoft, MS-DOS, Windows, and Windows NT are registered trademarks of Microsoft Corporation. Novell and NetWare are registered trademarks of Novell, Inc. UNIX is a registered trademark in the United States and other countries, licensed exclusively through X/Open Company, Ltd.

Netscape Navigator is a registered trademark of Netscape Communications.

JavaScript is a trademark of Sun Microsystems.

All other company and product names may be trademarks of the respective companies with which they are associated.

ENVIRONMENTAL STATEMENT

It is the policy of 3Com Corporation to be environmentally-friendly in all operations. To uphold our policy, we are committed to:

Establishing environmental performance standards that comply with national legislation and regulations.

Conserving energy, materials and natural resources in all operations.

Reducing the waste generated by all operations. Ensuring that all waste conforms to recognized environmental standards. Maximizing the recyclable and reusable content of all products.

Ensuring that all products can be recycled, reused and disposed of safely.

Ensuring that all products are labelled according to recognized environmental standards.

Improving our environmental record on a continual basis.

End of Life Statement

3Com processes allow for the recovery, reclamation and safe disposal of all end-of-life electronic components.

Regulated Materials Statement

3Com products do not contain any hazardous or ozone-depleting material.

Environmental Statement about the Documentation

The documentation for this product is printed on paper that comes from sustainable, managed forests; it is fully biodegradable and recyclable, and is completely chlorine-free. The varnish is environmentally-friendly, and the inks are vegetable-based with a low heavy-metal content.

CONTENTS

ABOUT THIS GUIDE

Conventions	8
Related Documentation	9
Accessing Online Documentation	9
Product Registration	10
Documentation Comments	10

1 INTRODUCING THE SUPERSTACK 3 SWITCH 4900 SERIES

About the Switches	12
Summary of Hardware Features	13
Switch — Front View Detail	14
100/1000BASE-T and 10/100/1000BASE-T Ports	16
1000BASE-SX Ports	16
GBIC Ports	16
LEDs	17
Switch — Rear View Detail	18
Unit Information Label	19
Power Socket	19
Redundant Power System Socket	19
Console Port	20
Expansion Module Slot	20
Default Settings	20

2 INSTALLING THE SWITCH

Package Contents	22
Choosing a Suitable Site	22
Rack-mounting	23
Placing Units On Top of Each Other	24
Creating an XRN Distributed Fabric	24
How To Interconnect Units	25

Rules For Interconnecting Units	25
The Power-up Sequence	26
Powering-up the Switch	26
Checking for Correct Operation of LEDs	26
Connecting a Redundant Power System	27
Choosing the Correct 10/100/1000BASE-T Cables	27
Choosing the Correct Fiber Cables	28
Switch 4950 — GBIC Operation	29
Approved GBIC Transceivers	29
Inserting a GBIC Transceiver	29

3 SETTING UP FOR MANAGEMENT

Setting Up Overview	34
IP Configuration	35
Preparing for Management	36
Manually Configuring IP Information	37
Connecting to a Front Panel Port	37
Connecting to the Console Port	40
Viewing Automatically Configured IP Information	43
Using 3Com Network Supervisor	43
Connecting to the Console Port	44
Methods of Managing a Switch	46
Command Line Interface Management	46
Web Interface Management	47
SNMP Management	47
Setting Up Command Line Interface Management	48
CLI Management via the Console Port	48
CLI Management over the Network	48
Setting Up Web Interface Management	49
Pre-requisites	49
Web Management Over the Network	50
Setting Up SNMP Management	51
Pre-requisites	51
Default Users and Passwords	51
Changing Default Passwords	52

4 PROBLEM SOLVING

- Solving Problems Indicated by LEDs 54
- Solving Hardware Problems 55
- Solving Communication Problems 57
- Solving Software Upgrade Problems 58

A SAFETY INFORMATION

- Important Safety Information 60
- L'information de Sécurité Importante 63
- Wichtige Sicherheitsinformationen 66

B PIN-OUTS

- Null Modem Cable 69
- PC-AT Serial Cable 69
- Modem Cable 70
- RJ-45 Pin Assignments 70

C TECHNICAL SPECIFICATIONS

D TECHNICAL SUPPORT

- Online Technical Services 75
 - World Wide Web Site 75
 - 3Com Knowledgebase Web Services 75
 - 3Com FTP Site 76
- Support from Your Network Supplier 76
- Support from 3Com 77
 - Email Support 77
 - Telephone Support 77
- Returning Products for Repair 79

INDEX

REGULATORY NOTICES

ABOUT THIS GUIDE

This guide provides all the information you need to install and use the following Switches in their default state:

- SuperStack® 3 Switch 4900 (3C17700)
- SuperStack® 3 Switch 4900 SX (3C17702)
- SuperStack® 3 Switch 4924 (3C17701)
- SuperStack® 3 Switch 4950 (3C17706)



This guide is intended for use with all the 4900 Series Switches listed above. For illustrative purposes all pictures and example screens show the 4900 model, however, all procedures apply to all the other Switches listed unless otherwise stated.

The guide is intended for use by network administrators who are responsible for installing and setting up network equipment; consequently, it assumes a basic working knowledge of LANs (Local Area Networks).



If the information in the release notes that are shipped with your product differ from the information in this guide, follow the instructions in the release notes.

Most user guides and release notes are available in Adobe Acrobat Reader Portable Document Format (PDF) or HTML on the 3Com World Wide Web site:

<http://www.3com.com/>

Conventions

[Table 1](#) and [Table 2](#) list conventions that are used throughout this guide.

Table 1 Notice Icons



Icon	Notice Type	Description
	Information note	Information that describes important features or instructions.
	Caution	Information that alerts you to potential loss of data or potential damage to an application, system, or device.
	Warning	Information that alerts you to potential personal injury.

Table 2 Text Conventions

Convention	Description
Screen displays	This typeface represents information as it appears on the screen.
Syntax	The word “syntax” means that you must evaluate the syntax provided and then supply the appropriate values for the placeholders that appear in angle brackets. Example: To change your password, use the following syntax: <pre>system password <password></pre> In this example, you must supply a password for <password>.
Commands	The word “command” means that you must enter the command exactly as shown and then press Return or Enter. Commands appear in bold. Example: To display port information, enter the following command: <pre>bridge port detail</pre>
The words “enter” and “type”	When you see the word “enter” in this guide, you must type something, and then press Return or Enter. Do not press Return or Enter when an instruction simply says “type.”
Keyboard key names	If you must press two or more keys simultaneously, the key names are linked with a plus sign (+). Example: Press Ctrl+Alt+Del
Words in <i>italics</i>	Italics are used to: <ul style="list-style-type: none"> ■ Emphasize a point. ■ Denote a new term at the place where it is defined in the text. ■ Identify menu names, menu commands, and software button names. Examples: From the <i>Help</i> menu, select <i>Contents</i>. Click <i>OK</i>.

Related Documentation

In addition to this guide, each Switch documentation set includes the following:

- *SuperStack 3 Management Quick Reference Guide*

This guide contains:

- a list of software features supported by each Switch.
- a summary of the web interface and command line interface commands for the Switch.

- *Release Notes*

These notes provide information about the current software release, including new features, modifications, and known problems.

- *SuperStack 3 Switch Implementation Guide*

This guide contains information on the features supported by your Switch and how they can be used to optimize your network. It is supplied in PDF format on the CD-ROM that accompanies the Switch.

- *Management Interface Reference Guide*

This guide provides detailed information about the web interface and command line interface that enable you to manage the Switch. It is supplied in HTML format on the CD-ROM that accompanies the Switch.

There are other publications you may find useful:

- Documentation accompanying the Advanced Redundant Power System.
- Documentation accompanying the Expansion Modules.
- Documentation accompanying 3Com Network Supervisor. This is supplied on the CD-ROM that accompanies the Switch.

Accessing Online Documentation

The CD-ROM supplied with your Switch contains the following online documentation:

- SuperStack 3 Switch Implementation Guide (PDF format)
- SuperStack 3 Switch Management Interface Reference Guide (HTML format)
- Other documentation relating to the Switch 4900 Series (PDF format)

To access the online documentation from the CD-ROM:

- 1 Insert the CD-ROM into the relevant CD-ROM drive. If your PC has auto-run enabled, a splash screen will be displayed automatically.
- 2 Select the Documentation section from the contents page.

If the online documentation is to be accessed from a local drive or server, you will need to access the CD-ROM contents via the root directory and copy the files from the CD-ROM to a suitable directory.

- The HTML Reference Guide is stored in the `Docs/referenceguide` on the CD-ROM. The documentation is accessed using the `index.htm` file.
- The PDF Implementation Guide is stored in the `Docs/implementation` directory of the CD-ROM.



3Com recommends that you copy the `Docs/referenceguide` directory as a whole to maintain the structure of the files.

Product Registration

You can register your SuperStack 3 Switch on the 3Com Web site to receive up-to-date information on your product:

<http://support.3com.com/registration/frontpg.pl>

Documentation Comments

Your suggestions are very important to us. They will help make our documentation more useful to you. Please e-mail comments about this document to 3Com at:

pddtechpubs_comments@3com.com

Please include the following information when commenting:

- Document title
- Document part number (on the title page)
- Page number (if appropriate)

Example:

Part Number DUA1770-0AAA0x

SuperStack 3 Switch 4900 Series Getting Started Guide

Page 21

1

INTRODUCING THE SUPERSTACK 3 SWITCH 4900 SERIES

This chapter contains introductory information about the Switch 4900, 4900 SX, 4924 and 4950 and how they can be used in your network. It covers summary information about the hardware.



The information for all the Switches in the Switch 4900 Series is the same unless otherwise stated.

- [About the Switches](#)
 - [Summary of Hardware Features](#)
- [Switch — Front View Detail](#)
 - [100/1000BASE-T and 10/100/1000BASE-T Ports](#)
 - [1000BASE-SX Ports](#)
 - [GBIC Ports](#)
 - [LEDs](#)
- [Switch — Rear View Detail](#)
 - [Unit Information Label](#)
 - [Power Socket](#)
 - [Redundant Power System Socket](#)
 - [Console Port](#)
 - [Expansion Module Slot](#)
- [Default Settings](#)

About the Switches

- The Switch 4900 connects your existing 100 Mbps devices and high-performance workgroups with a 1000 Mbps copper backbone or server connection.
- The Switch 4900 SX connects your existing 1000 Mbps devices and high-performance workgroups with a 1000BASE-SX fiber backbone or server connection.
- The Switch 4924 connects your existing 10 Mbps and 100 Mbps devices and high-performance workgroups to a 1000 Mbps copper backbone or server connection.
- The Switch 4950 is a 10/100/1000 Mbps mixed media device that allows you to connect your existing 10/100/1000 Mbps devices and high-performance workgroups to a fiber or copper gigabit backbone or server connection.

You can also interconnect any combination of two Switches from the SuperStack® 4900 Series or 3Com Switch 4050/4060 range to create an XRN Distributed Fabric. This allows you to create a highly resilient core around which you can build your network. For more information about interconnecting Switches, see [“Creating an XRN Distributed Fabric”](#) on [page 24](#). For more information about 3Com XRN Technology and how to use it in your network, refer to the Implementation Guide on the CD-ROM that accompanies the Switch.



For information about using the software features of the Switch, refer to the “SuperStack 3 Switch Management Interface Reference Guide” on the CD-ROM that accompanies the Switch.

Summary of Hardware Features

[Table 3](#) summarizes the hardware features that are supported by the Switches.

Table 3 Hardware features

Feature	Switch 4900 Series
Fast Ethernet and Gigabit Ethernet Ports	<p>Switch 4900: 12 Auto-negotiating 100BASE-TX/1000BASE-T ports</p> <p>Switch 4900 SX: 12 Auto-negotiating 1000BASE-SX ports</p> <p>Switch 4924: 24 Auto-negotiating 10BASE-T/100BASE-TX/1000BASE-T ports</p> <p>Switch 4950: 12 Auto-negotiating 10BASE-T/100BASE-TX/1000BASE-T, 6 1000BASE-SX and 6 GBIC ports</p>
Addresses	<ul style="list-style-type: none"> ■ Up to 12,000 supported ■ Up to 64 permanent entries
Forwarding Modes	Store and Forward
Duplex Modes	<ul style="list-style-type: none"> ■ Half duplex only supported on 10BASE-T/100BASE-TX/1000BASE-T ports in 10/100 Mbps mode ■ All 1000 Mbps ports are full duplex only
Flow Control	Supported on all ports
Smart auto-sensing	<ul style="list-style-type: none"> ■ Supported on all 10BASE-T/100BASE-TX/1000BASE-T ports ■ Not supported on 1000BASE-SX and GBIC ports
Traffic Prioritization	Supported (IEEE Std 802.1D, 1998 Edition) Four traffic queues per port
Layer 3 Switching	Support for wire-speed IP routing
RPS Support	Connects to SuperStack 3 Advanced Redundant Power System (ARPS) (3C16071B)
XRN Support	eXpandable Resilient Networking (XRN) support. Allows interconnection of two units to create a Distributed Fabric.
Mounting	19-inch rack or stand-alone mounting

Switch — Front View Detail

Figure 1 Switch 4900 — front view

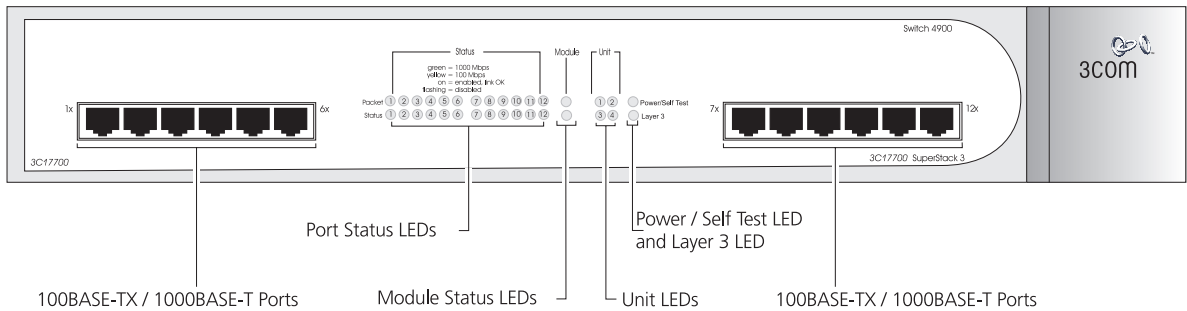

Figure 2 Switch 4900 SX — front view

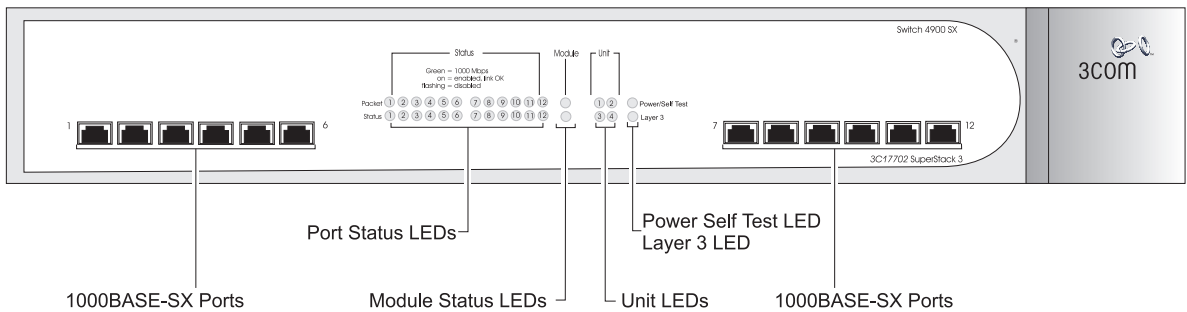

Figure 3 Switch 4924 — front view

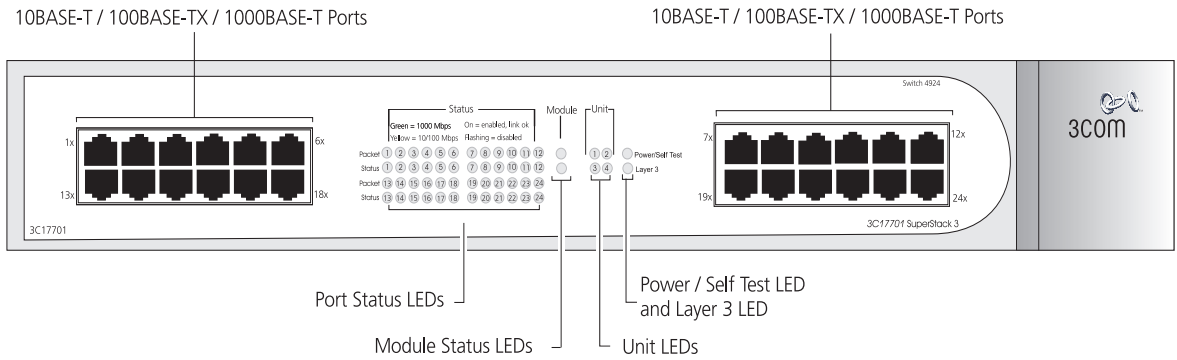
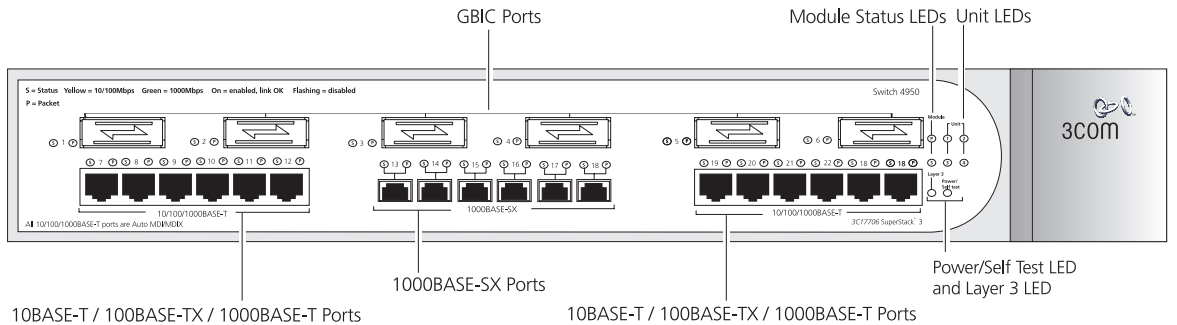

Figure 4 Switch 4950 — front view



WARNING: RJ-45 Ports. These are shielded RJ-45 data sockets. They cannot be used as standard traditional telephone sockets, or to connect the unit to a traditional PBX or public telephone network. Only connect RJ-45 data connectors, network telephony systems, or network telephones to these sockets.

Either shielded or unshielded data cables with shielded or unshielded jacks can be connected to these data sockets.

100/1000BASE-T and 10/100/1000BASE-T Ports

The 100BASE-TX/1000BASE-T and 10BASE-T/100BASE-TX/1000BASE-T ports have RJ-45 connectors and are configured as Auto MDIX (cross-over).

The default state for these ports is auto-negotiation enabled, where the speed, duplex and flow control modes of a link are automatically detected to provide the highest available bandwidth with the link partner.

Alternatively, auto-negotiation can be disabled. These ports can be manually configured to 10 Mbps half duplex (if supported), 100 Mbps half duplex, 10 Mbps full duplex (if supported), or 100 Mbps full duplex. It is not possible to manually configure a 1000BASE-T link as auto-negotiation is mandatory in the 1000BASE-T standard.

The maximum segment length is 100 m (328 ft) over Category 5 twisted pair cable.



1000BASE-T operation only supports full-duplex mode.



10BASE-T (10 Mbps) is only supported on Switch 4924 and 4950.

1000BASE-SX Ports

The default state for these ports is auto-negotiation enabled, where the speed, duplex and flow control modes are negotiated. As the speed and duplex modes are fixed by the media type, only the flow control is negotiated with the link partner. Alternatively, auto-negotiation can be disabled and the flow control setting can be manually configured.



1000BASE-SX ports do not support auto-negotiation of speed and only support full duplex mode.

GBIC Ports

GBIC ports support fiber Gigabit Ethernet short-wave (SX), long-wave (LX) and long-haul (LH70) GBIC transceivers in any combination. This offers you the flexibility of using GBIC transceivers to provide connectivity between the Switch and remote 1000 Mbps workgroups or to create a high capacity aggregated link backbone connection.

The default state for these ports is auto-negotiation enabled, where the speed, duplex and flow control modes are negotiated. As the speed and duplex modes are fixed by the media type, only the flow control is negotiated with the link partner. Alternatively, auto-negotiation can be disabled and the flow control setting can be manually configured.

LEDs [Table 4](#) lists LEDs visible on the front of the Switch, and how to read their status according to color. For information on using the LEDs for problem solving, see [“Checking for Correct Operation of LEDs”](#) on [page 26](#).

Table 4 LED behavior

LED	Color	Indicates
Port Status LEDs		
Packet	Yellow	Packets are being transmitted/received on the port.
	Off	No packets are being transmitted/received on the port.
Status	Green	A high speed (1000 Mbps) link is present, and the port is enabled.
	Green flashing	A high speed (1000 Mbps) link is present, but the port is disabled.
	Yellow	A low speed (100 Mbps on 4900, 10/100 Mbps on 4924/4950) link is present, and the port is enabled. (Not applicable on 4900 SX.)
	Yellow flashing	A low speed (100 Mbps on 4900, 10/100 Mbps on 4924/4950) link is present, but the port is disabled. (Not applicable on 4900 SX.)
	Off	No link is present.
Module Status LEDs		
	Green	The Module is installed and supported. The Link Status has been determined for a single port Module.
	Yellow	The Module is installed and supported. The Module has multi-ports or there is no Link for a single port Module.
	Yellow flashing	The Module is installed but not supported. Note that the Switch will continue to operate normally.
	Off	The Module is not installed.
Unit LEDs		
1–4	Green	Determines the identity of the Switch when interconnected to another Switch to create an XRN Distributed Fabric and that a link is present.
	Off	A fault has occurred.
Power/Self Test LED		
	Green	The Switch is powered-up and operating normally.
	Green flashing	The Switch is either downloading software or is initializing (which includes running a Power On Self Test).
	Yellow	The Switch has failed its Power On Self Test.
	Off	The Switch is not receiving power.

LED	Color	Indicates
Layer 3 LED		
	Green	The Switch software supports Layer 3.
	Off	The Switch software does not support Layer 3.

Switch — Rear View Detail

Figure 5 Switch 4900 — rear view

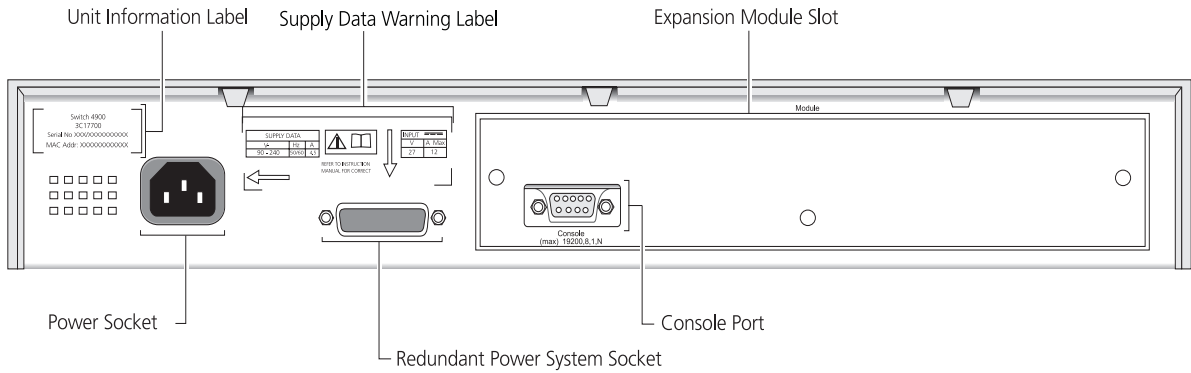

Figure 6 Switch 4900 SX — rear view

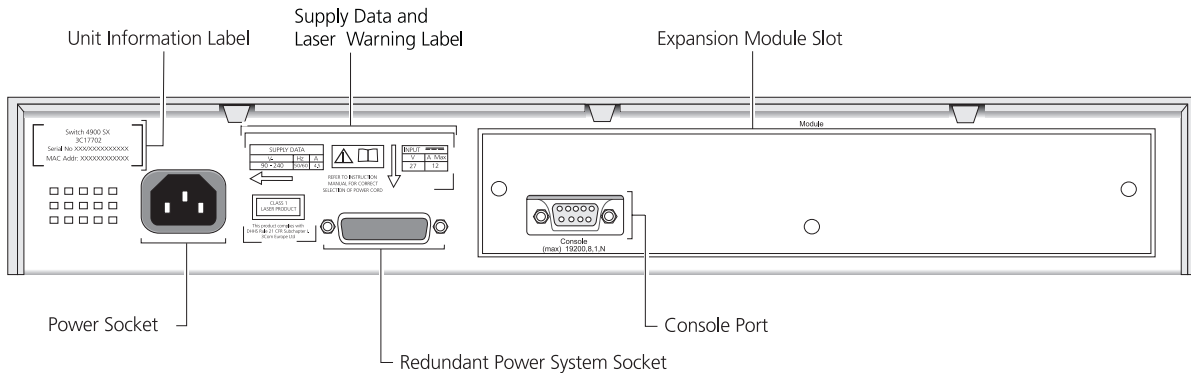
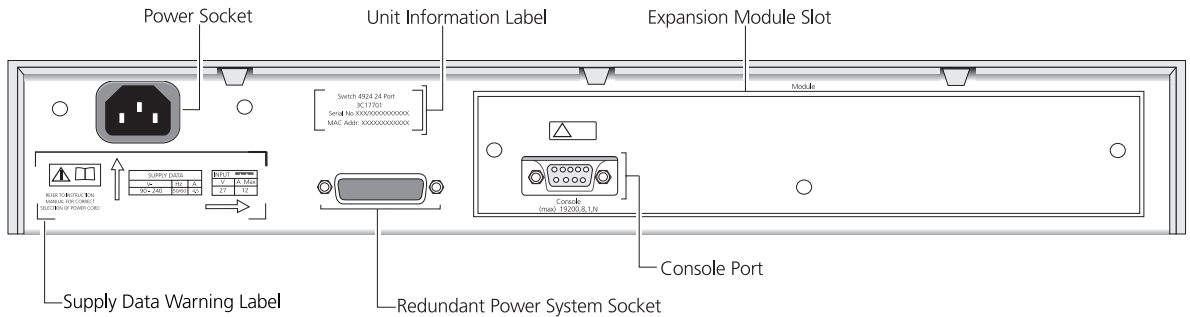
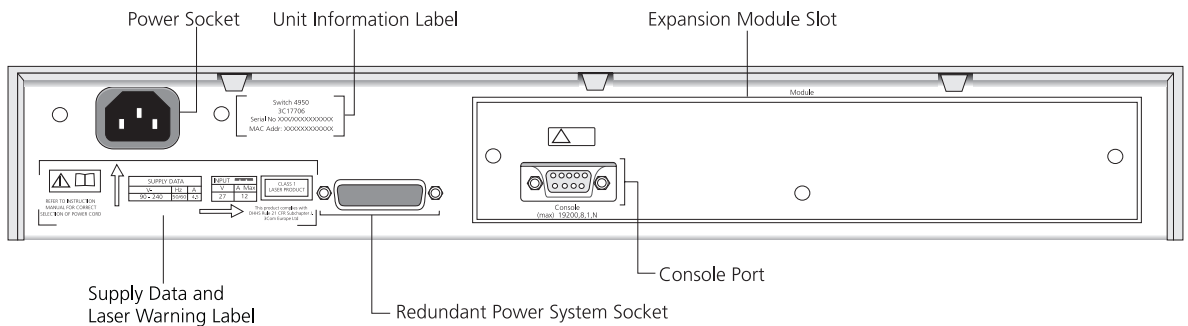

Figure 7 Switch 4924 — rear view**Figure 8** Switch 4950 — rear view

Unit Information Label

This label shows the following:

- The 3Com product name of the Switch
- The 3Com 3C number of the Switch
- The unique MAC address (Ethernet address) of the Switch
- The serial number of the Switch

You may need this information for fault reporting purposes.

Power Socket

The Switch automatically adjusts its power setting to any supply voltage in the range 90-240 VAC.

Redundant Power System Socket

To protect against internal power supply failure, you can use this socket to connect a SuperStack 3 Advanced Redundant Power System (RPS) to the Switch. See ["Connecting a Redundant Power System"](#) on [page 27](#).

Console Port The console port allows you to connect a terminal and perform remote or local out-of-band management. The console port uses a standard null modem cable and is set to auto-baud (up to a maximum of 19200 baud), 8 data bits, no parity and 1 stop bit.

Expansion Module Slot You can use this slot to install an Expansion Module. Contact your supplier for further information on the range of Expansion Modules supported by your Switch.



WARNING: When an Expansion Module is not installed, ensure the blanking plate is fitted by tightening all screws with a suitable tool.

Default Settings

[Table 5](#) shows the default settings for the Switches. If you initialize one of the Switch units, it is returned to these defaults.

Table 5 Default Setting

Feature	Switch 4900 Series
Port Status	Enabled
Port Speed	Auto-negotiated
Duplex Mode	Auto-negotiated
Flow Control	Auto-negotiated
Broadcast Storm Control	Enabled High threshold: 3000 broadcast frames per second — Notify and filter Low threshold: 1500 broadcast frames per second — Notify and unfilter
Virtual LANs (VLANs)	All ports belong to the untagged Default VLAN (VLAN 1)
Multicast Filtering	IGMP filtering enabled
Rapid Spanning Tree Protocol	Enabled
Link Aggregation Control Protocol (LACP)	Enabled
Smart Auto-sensing	Switch 4900, 4924, and 4950: Enabled Switch 4900 SX: Not applicable
IP Address	169.254.100.100*
Subnet Mask	255.255.0.0

* This default IP address is used if the unit is operating in standalone mode, and/or no other Switches on the network have this IP address. If this default IP address is already in use then the Switch detects this and configures itself with an IP address in the range 169.254.1.0 to 169.254.254.255.

2

INSTALLING THE SWITCH

This chapter contains the information you need to install and set up the Switch. It covers the following topics:

- [Package Contents](#)
- [Choosing a Suitable Site](#)
- [Rack-mounting](#)
- [Placing Units On Top of Each Other](#)
- [Creating an XRN Distributed Fabric](#)
- [The Power-up Sequence](#)
- [Switch 4950 — GBIC Operation](#)



WARNING: Safety Information. Before installing or removing any components from the Switch or carrying out any maintenance procedures, you must read the safety information provided in [Appendix A](#) of this guide.



AVERTISSEMENT: Consignes de sécurité. Avant d'installer ou d'enlever tout composant du Switch ou d'entamer une procédure de maintenance, lisez les informations relatives à la sécurité qui se trouvent dans l'Appendice A de ce guide.



VORSICHT: Sicherheitsinformationen. Bevor Sie Komponenten aus dem Switch entfernen oder dem Switch hinzufuegen oder Instandhaltungsarbeiten verrichten, lesen Sie die Sicherheitsanweisungen, die in Anhang A in diesem Handbuch aufgefuehrt sind.

Package Contents

- Switch unit
- CD-ROM
- This Guide
- Management Quick Reference Guide
- Release Notes
- Warranty Flyer
- Power Cord
- 2 x securing brackets
- 6 x screws
- 4 x rubber feet

Choosing a Suitable Site

The Switch is suited for use in an internal wiring closet, a network room, or telecommunications room, where it can be mounted in a standard 19-inch equipment rack, or free-standing.



CAUTION: *Ensure that the ventilation holes are not obstructed.*



To ensure this product provides optimum performance, high speed fans are used to provide ventilation. These fans have a high audible output.

When deciding where to position the Switch, ensure that:

- Cabling is located away from:
 - sources of electrical noise such as radios, transmitters and broadband amplifiers.
 - power lines and fluorescent lighting fixtures.
- The Switch is accessible and cables can be connected easily.
- Water or moisture cannot enter the case of the Switch.
- Air flow is not restricted around the Switch or through the vents in the side of the Switch. 3Com recommends that you provide a minimum of 25 mm (1 in.) clearance.
- Air temperature around the Switch does not exceed 40 °C (104 °F).



If the Switch is installed in a 19-inch rack or closed assembly its local air temperature may be greater than room ambient temperature.

- The air is as free from dust as possible.
- The unit is installed in a clean, air conditioned environment.
- No more than four Switch units are placed on top of one another, if the units are free-standing.
- The Switch is situated away from sources of conductive (electrical) dust, for example laser printers.
- The AC supply used by the Switch is separate to that used by units that generate high levels of AC noise, for example air conditioning units and laser printers.

Rack-mounting

The Switch is 1.5U and will fit in most standard 19-inch racks. However, as each Switch requires a shelf or runner to support its weight, you may need to allow a 2U space within the rack for each Switch.



WARNING: *The Switch should only be used in a rack if it is mounted on runners, a shelf, or a tray to support the weight. The rack-mount kits alone are not sufficient to support the weight of the switch. The rack-mount kits must not be used to suspend the Switch from under a table or desk, or attach it to a wall.*



CAUTION: *Disconnect all cables from the Switch before continuing. Remove all self adhesive pads from the underside of the Switch if they have been fitted.*



CAUTION: *You must use a shelf or support that will not obstruct the air flow through the side panels of the Switch.*

To rack-mount your Switch:

- 1 Place the Switch the right way up on a hard flat surface, with the front facing towards you.
- 2 Locate a securing bracket over the mounting holes on one side of the Switch, as shown in [Figure 9](#).
- 3 Insert the three screws and tighten with a suitable screwdriver.

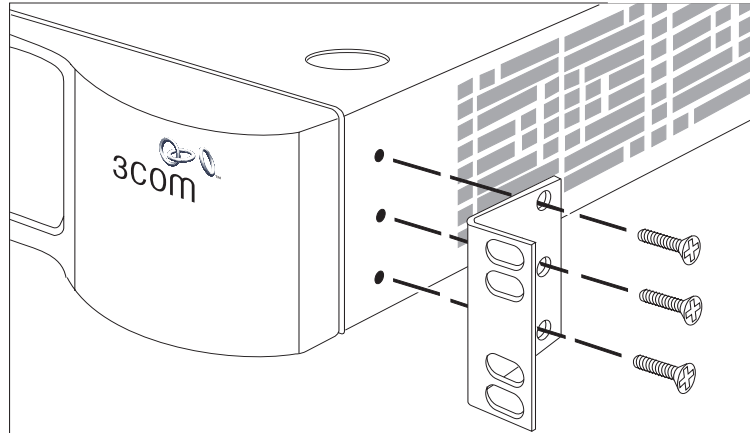
Figure 9 Fitting a bracket for rack-mounting

You must use the screws supplied with the securing brackets. Damage caused to the unit by using incorrect screws invalidates your warranty.

- 4** Repeat steps 2 and 3 for the other side of the Switch.
- 5** Insert the Switch into the 19-inch rack and secure with suitable screws (not provided). Ensure that ventilation holes are not obstructed.
- 6** Connect network cabling.

Placing Units On Top of Each Other

If the Switch units are free-standing, up to four units can be placed one on top of the other. If you are mixing a variety of SuperStack® 3 Switch and Hub units, the smaller units must be positioned at the top.

If you are placing Switch units one on top of the other, you must use the self-adhesive rubber pads supplied. Apply the pads to the underside of each Switch, sticking one in the marked area at each corner. Place the Switch units on top of each other, ensuring that the pads of the upper unit line up with the recesses of the lower unit.

Creating an XRN Distributed Fabric

Switch 4900 Series units and 3Com Switch 4050/4060 units can be interconnected to create an XRN Distributed Fabric and then treated as a single manageable unit with one IP address. A combination of any two of these units is allowed to be interconnected.

How To Interconnect Units

To interconnect any two Switch 4900 Series or Switch 4050/4060 units you will need to order the XRN Interconnect Module Kit (3C17715). The kit consists of two XRN Interconnect Modules and an Interconnect Cable. Both Switches must have an unused expansion slot to allow an Interconnect Module to be fitted.

Figure 10 Interconnecting two Switch 4900 units

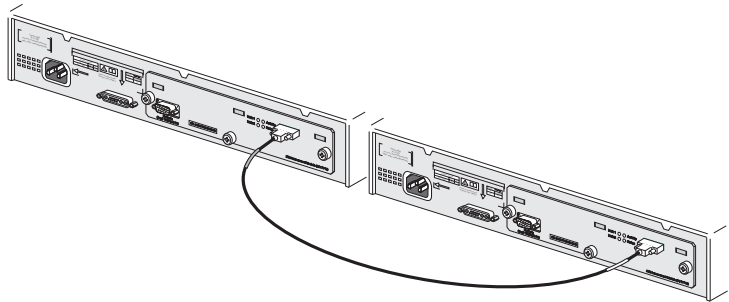

For information on ordering the XRN Interconnect Kits contact your supplier. For illustrations and information on how to install the XRN Interconnect Kits, refer to the user documentation that accompanies these Kits.

Rules For Interconnecting Units

This information is also provided in the user documentation that accompanies the XRN Interconnect Kits.

- The maximum number of Switch units that can be interconnected is two.
- XRN Interconnect Modules are NOT hot-swappable or hot-insertable. Ensure that the Switch is powered off before inserting or removing an Interconnect Module.
- Only 3Com XRN Interconnect Cables can be used to connect two Interconnect Modules.
- It is not possible to interconnect the Switch 4900 Series and Switch 4050/4060 units with any other 3Com device.
- 3Com strongly recommends that you upgrade all Switches to be interconnected to the latest software agent.
- 3Com recommends that you initialize a Switch unit that has previously been used elsewhere in your network before you interconnect to an

existing unit. If you do not initialize the unit, problems may be caused by conflicting Switch configurations.

- When the Switch units are interconnected they are assigned a unit number dependent on which XRN Interconnect Cable end is connected to which Switch. That is, the Switch with the blue cable end will be assigned the identity of Unit 1 and the Switch with the yellow cable end will be assigned the identity of Unit 2.



For a detailed description of how XRN Technology operates and implementation guidelines, please refer to the Implementation Guide on the CD-ROM that accompanies your Switch or on the 3Com Web site.

The Power-up Sequence

The following sections describe how to get your Switch powered-up and ready for operation.

Powering-up the Switch

Use the following sequence of steps to power-up the Switch.

- 1 Plug the power cord into the power socket at the rear of the Switch.
- 2 Plug the other end of the power cord into your power outlet.

The Switch powers-up and runs through its Power On Self Test (POST), which takes approximately 10 seconds.

Checking for Correct Operation of LEDs

During the Power On Self Test, all ports on the Switch are disabled and the LEDs light in a rapid sequence.

When the POST has completed, check the Power/Self Test LED to make sure that your Switch is operating correctly. [Table 6](#) shows possible colors for the LED.

Table 6 Power/Self Test LED Colors

Color	State
Green	The Switch is powered-up and operating normally.
Yellow	The Switch has failed its Power On Self Test (POST) because of an internal problem.
Off	The Switch is not receiving power.

If there is evidence of a problem, see [“Solving Problems Indicated by LEDs”](#) on [page 54](#) for a list of suggested solutions.

Connecting a Redundant Power System

You can connect a SuperStack 3 Advanced Redundant Power System to the Switch. This unit, which is also known as an RPS, is designed to maintain the power to your Switch if a power supply failure occurs.

For normal redundancy, the unit requires one Type 3 Power Module (part number 3C16075).

For full redundancy, the unit requires two Type 3 Power Modules combined using a Type 3 Y-Cable (part number 3C16077).



WARNING: *If you are connecting the Switch to a Type 3 Power Module, read the Safety Information section in the Type 3 Power Module User Guide.*



CAUTION: *The Switch can only use a SuperStack Advanced Redundant Power System output.*



CAUTION: *The Switch has no ON/OFF switch; the only method of connecting or disconnecting mains power is by connecting or disconnecting the power cord.*

Choosing the Correct 10/100/1000BASE-T Cables

If your Switch has 10/100/1000BASE-T ports, these ports are Auto-MDIX, that is they have a cross-over capability. These ports can automatically detect whether to operate in MDI or MDIX mode. Therefore you can make a connection to one of the ports with a straight-through (MDI) or a cross-over cable (MDIX).



The Auto-MDIX feature only operates when auto-negotiation is enabled.

If auto-negotiation is disabled, all the Switch ports are configured as MDIX (cross-over). If you want to make a connection to another MDIX port, you need a *cross-over* cable. Many ports on workstations and servers are configured as MDI (straight-through). If you want to make a connection to an MDI port, you need to use a standard *straight-through* cable. See [Table 7](#).

3Com recommends that you use at least Category 5 twisted pair cable — the maximum segment length for this type of cable is 100 m (328 ft).

Table 7 Cables required to connect the Switch to other devices if auto-negotiation is disabled

	Cross-over Cable	Straight-through Cable
Switch to Switch (MDIX to MDIX)	✓	✗
Switch to Hub (MDIX to MDIX)	✓	✗
Switch to PC (NIC) (MDIX to MDI)	✗	✓



CAUTION: If you want to install the Switch using a Category 5E or Category 6 cable, 3Com recommends that you briefly connect the cable to a grounded port before connecting network equipment. If you do not, the cable's Electrostatic Discharge (ESD) may damage the Switch's port.

You can create a grounded port by connecting all wires at one end of a UTP cable to an earth ground point, and the other end to a female RJ-45 connector located, for example, on a Switch rack or patch panel. The RJ-45 connector is now a grounded port.

Choosing the Correct Fiber Cables

If your Switch has fiber ports you can choose from the following cable options:

- The 1000BASE-SX ports can be connected to multimode fiber cables only.
- The 1000BASE-LX and 1000BASE-LH70 GBIC ports use multimode or single-mode fiber optic cables.



CAUTION: 3Com recommends that you use MT-RJ cables that do not contain alignment pins as these are provided by the fiber socket. Cables that contain alignment pins can cause damage to your Switch.



For detailed information on fiber cable specifications, refer to the *SuperStack 3 Implementation Guide* on the CD-ROM that accompanies your Switch.



If you wish to connect a 1000BASE-SX MT-RJ port to a fiber port with a different type of connector, for example, SC or ST please contact your network supplier for a suitable patch cable.

Switch 4950 — GBIC Operation

The following sections describes how to insert a GBIC transceiver into a GBIC port on a Switch 4950.



GBIC transceivers are hot-insertable and hot-swappable. You can remove them from and insert them into any GBIC port without having to power down the Switch.

Approved GBIC Transceivers

The following list of approved GBIC transceivers is correct at the time of publication.



WARNING: *The Switch must only be fitted with 3Com approved GBIC transceivers, as listed below.*

- 3CGBIC91 GBIC (SX)
- 3CGBIC92 GBIC (LX)
- 3CGBIC97 GBIC (LH70)

To access the latest list of approved GBIC transceivers for the Switch on the 3Com Corporation World Wide Web site, enter this URL into your internet browser:

`http://www.3com.com`



The URL is case sensitive.

Inserting a GBIC Transceiver

To be recognised as valid, the GBIC transceiver must have the following characteristics:

- 1000BASE-SX, 1000BASE-LX or 1000BASE-LH70 media type:
 - 1000BASE-SX GBIC transceiver

Use this transceiver to connect the Switch directly to a multimode fiber-optic cable.
 - 1000BASE-LX GBIC transceiver

Use this transceiver to connect the Switch directly to a single-mode fiber-optic cable or to multimode fiber using a conditioned launch cable.
 - 1000BASE-LH70 GBIC transceiver

Use this transceiver to connect the Switch directly to a single-mode fiber-optic cable or to multimode fiber using a conditioned launch cable.

- Fiber SC connector
- Type 4 GBIC with internal EEPROM fitted.



If the GBIC transceiver is faulty, it will not operate within the Switch. See [“Solving Hardware Problems”](#) on [page 55](#).



Do not use non-3Com GBICs. If the GBIC transceiver is invalid it will not be recognised by the Switch.

Use the following sequence of steps to activate the GBIC ports.

- 1 To insert one of the transceivers into a GBIC expansion port on the Switch:
 - a Orient the transceiver so that the fiber-optic duplex subscriber connector (SC) is toward you, as shown in [Figure 11](#).
 - b Gently slide the transceiver into the GBIC port until it clicks into place.
- 2 If you wish to remove the transceiver, compress the side tabs and gently pull the transceiver out of the port.



CAUTION: *GBIC transceivers are keyed and can be properly inserted only one way. If the transceiver does not click when you insert it, remove it, turn it over, and reinsert it.*

Figure 11 Inserting a GBIC Transceiver into a Switch 4950

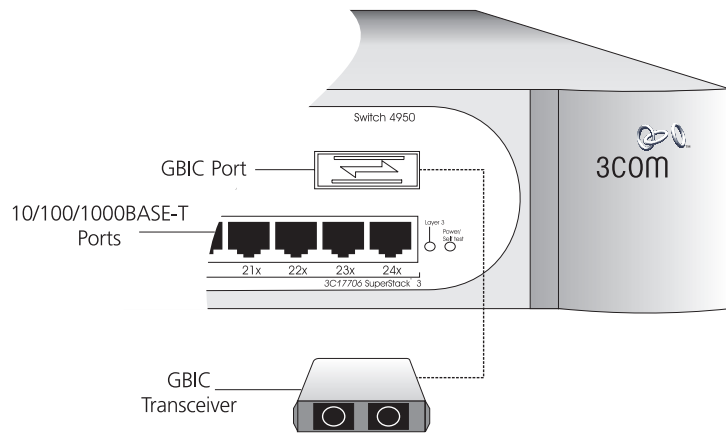

- 3** The transceiver connects to the network using a duplex SC connector. Attach a male duplex SC connector on the network cable into the duplex SC connector on the transceiver.
- 4** Connect the other end of the cable to a device fitted with an appropriate Gigabit Ethernet connection.
- 5** Check the LEDs on the front of the Switch to ensure that it is operating correctly. Refer to [“LEDs”](#) on [page 17](#) for more information.

3

SETTING UP FOR MANAGEMENT

Your Switch can operate in its default state, that is, you can install it and it will work straight away (plug-and-play). However, to make full use of the features offered by the Switch, and to change and monitor the way it works, you have to access the management software that resides on the Switch. This is known as managing the Switch.

Managing the Switch can help you to improve the efficiency of the Switch and therefore the overall performance of your network.

This chapter explains the initial set up of the Switch and the different methods of accessing the management software to manage a Switch. It covers the following topics:

- [Setting Up Overview](#)
- [Manually Configuring IP Information](#)
- [Viewing Automatically Configured IP Information](#)
- [Methods of Managing a Switch](#)
- [Setting Up Command Line Interface Management](#)
- [Setting Up Web Interface Management](#)
- [Setting Up SNMP Management](#)
- [Default Users and Passwords](#)

Setting Up Overview

This section gives an overview of what you need to do to get your Switch set up and ready for management when it is in its default state. The whole setup process is summarised in [Figure 12](#). Detailed procedural steps are contained in the sections that follow. In brief, you need to:

- Configure IP information manually for your Switch or view the automatically configured IP information
- Prepare for your chosen method of management

Figure 12 Initial Switch Setup and Management Flow diagram

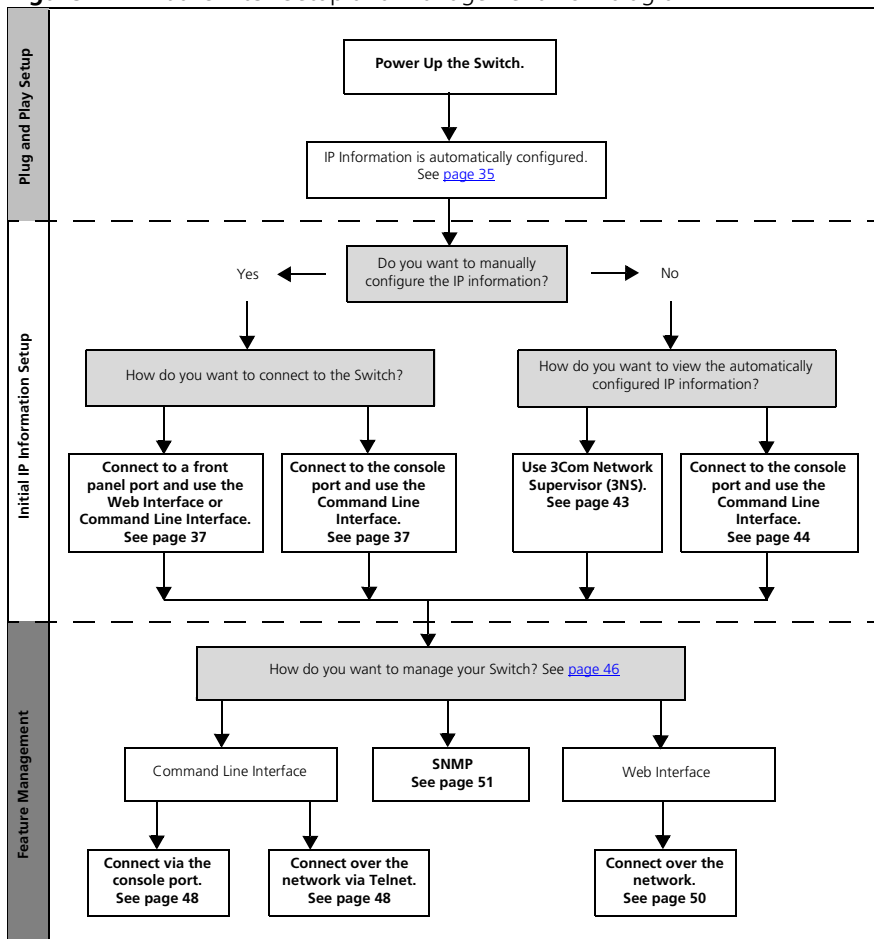

CAUTION: To protect your Switch from unauthorized access, you must change all three default passwords as soon as possible, even if you do not intend to actively manage your Switch. For more information on default

users and changing default passwords, see [“Default Users and Passwords”](#) on [page 51](#).

IP Configuration

You can use one of the following methods to allocate IP information to your Switch (essential if you wish to manage your Switch across the network).

Manual IP Configuration

You can choose to configure the IP information yourself. The Switch remembers the information that you enter until you change it again or set the configuration method to Automatic.

You should use the Manual IP configuration method if:

- you do not have a DHCP or BootP server on your network, or
- you want to remove the risk of the IP address ever changing, or
- your DHCP or BootP server does not allow you to allocate static IP addresses. (Static IP addresses are necessary to ensure that the Switch is always allocated the same IP information.)



For most installations, 3Com recommends that you configure the Switch IP information manually. This makes management simpler and more reliable as it is not dependent on a DHCP or BootP server, and eliminates the risk of the IP address changing.

If you wish to manually enter IP information for your Switch, work through the [“Manually Configuring IP Information”](#) section on [page 37](#).

Automatic IP Configuration

By default the Switch tries to configure itself with IP information without requesting user intervention. It tries to obtain an IP address from a DHCP or BootP server on the network.

If neither server is found, the Switch will configure itself with its default IP address 169.254.100.100 if it is operating in a standalone mode, and/or no other Switches on the network have this IP address. If this default IP address is already in use on the network then the Switch detects this and configures itself with an IP address in the range 169.254.1.0 to 169.254.254.255.

This process is known as Auto-IP and is the same mechanism used by Windows 98 and Windows 2000. IP addresses configured by Auto-IP are

temporary as they cannot be routed but are useful for small networks which are not connected to other networks, or for initial configuration.

However, as soon as a DHCP or BootP server is detected, the Switch will configure itself with the IP address allocated by that server.

When using automatic IP configuration it is important that the IP address of the Switch is static, otherwise you will not know what the IP address is and it will be difficult to manage. Most DHCP and BootP servers allow static IP addresses to be configured so that you know what IP address will be allocated to the Switch. Refer to the documentation that accompanies your DHCP/BootP server.



For a detailed description of how automatic IP configuration operates, please refer to the Implementation Guide on the CD-ROM that accompanies your Switch or on the 3Com Web site.

You should use the automatic IP configuration method if:

- your network uses DHCP or BootP to allocate IP information, or
- flexibility is needed. If the Switch is re-deployed onto a different subnet, it will automatically reconfigure itself with an appropriate IP address, instead of you having to manually reconfigure the Switch.

If you use the automatic IP configuration method, you need to discover the automatically allocated IP information before you can begin management. Work through the [“Viewing Automatically Configured IP Information”](#) section on [page 43](#).

Preparing for Management

Once your Switch’s initial set up is complete you can set up your chosen management method as described in [“Methods of Managing a Switch”](#) on [page 46](#).



For detailed information about the specific web interface operations and command line interface commands and problem solving, refer to the “Management Interface Reference Guide” on the CD-ROM that is supplied with the Switch or on the 3Com Web site.

Manually Configuring IP Information

You can manually configure the Switch IP information in the following ways:

- Connecting to a front panel port — Connect a workstation using an Ethernet cable to a front panel port of the Switch. You can then manually enter IP information using the web interface or the command line interface (CLI).
- Connecting to the console port — Connect a workstation using a console cable to the console port of the Switch. You can then manually enter IP information using the command line interface (CLI).

Connecting to a Front Panel Port

To set up your Switch manually you can make a connection to a front panel port. You must do this whilst the Switch is offline, that is, before you connect the Switch to a network.



The procedure described in this section assumes the unit has been powered up in standalone mode and has the default IP address of 169.254.100.100.

Pre-requisites

- A workstation running Windows 95/98/2000 or Windows NT.
- A Network Interface Card (NIC).
- A Category 5 twisted pair Ethernet cable with RJ-45 connectors.
- A suitable Web browser — refer to [“Choosing a Browser”](#) on [page 49](#).
- You need to have the following so that you can manually set up the Switch with IP information:
 - IP address
 - subnet mask
 - default gateway

Connecting the Workstation to the Switch

- 1 Connect the workstation to a front panel port using an Ethernet cable as shown in [Figure 13](#).

Figure 13 Connecting a workstation to the Switch via a front panel port

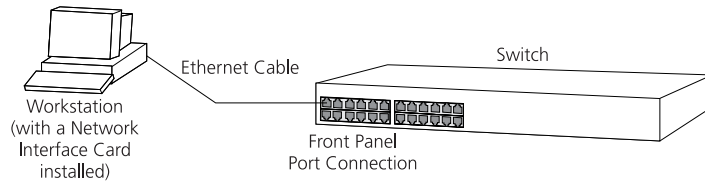

To connect the cable:

- a Attach an RJ-45 connector at one end of the Ethernet cable to the Network Interface Card (NIC) in the workstation.
- b Connect the RJ-45 connector at the other end of the cable to one of the front panel ports on the Switch.



Do not interconnect the Switch to any other unconfigured Switch.

Configuring the Workstation with IP Information

You need to change the IP address and subnet mask of the workstation that you have connected to the Switch. Make a note of the existing settings so you can return to them later. Change the workstation to the following settings:

- IP address — **169.254.100.99**
- Subnet mask — **255.255.0.0**

Setting Up the Switch with IP Information

You are now ready to manually set up the Switch with IP information. You can do this using the Web interface or the command line interface (CLI) via telnet.

Using the Web Interface

- 1 Power-up the Switch. This takes approximately one minute.
- 2 Open a suitable Web browser and enter **169.254.100.100** in the *Location Address* field. This is the default IP address that is automatically assigned to an offline unit.



If there is no response, wait for one minute then re-enter the default IP address.

- 3 At the login and password prompts, enter **admin** as your user name and press Return at the password prompt (default user name and password). If you have logged on correctly, a set of Getting Started pages are displayed.
- 4 The Getting Started pages allow you to enter basic setup information for the Switch. Select **Manual** and then enter the IP address, subnet mask, and default gateway that you want the Switch to use when it is connected to the network. The final page displays a summary of the information entered.

The initial set up of your Switch is now complete and the Switch is ready for you to set up your chosen management method. See [“Methods of Managing a Switch”](#) on [page 46](#).

Using Command Line Interface via Telnet

- 1 To start a Telnet session to the unit, click *Start* in Microsoft Windows 95/98/2000/NT.
 - a Click *Run*.
 - b In the dialogue box that appears type the default IP address of the unit, that is: **Telnet 169.254.100.100**
 - c Click *OK*.
- 2 Press *Enter* to open a login prompt.



If the login prompt does not begin immediately, press Return a few times until it starts.

- 3 At the login and password prompts, enter **admin** as your user name and press Return at the password prompt. If you have logged on correctly, the top-level menu of the command line interface is displayed as shown in the example in [Figure 14](#).

Figure 14 Example top-level command line interface menu

```

Menu options: -----3Com SuperStack 3 Switch 4xxx-----
bridge          - Administer bridge-wide parameters
feature         - Administer system features
gettingStarted  - Basic device configuration
logout         - Logout of the Command Line Interface
physicalInterface - Administer physical interfaces
protocol        - Administer protocols
security        - Administer security
system          - Administer system-level functions
trafficManagement - Administer traffic management

Type ? for help
----- (2)-----
Select menu option: █

```

4 At the Select menu option prompt you can either:

- enter the **protocol ip basicConfig** command. At the Enter configuration method prompt enter **manual**. The screen prompts you to enter IP information.

or

- enter the **gettingStarted** command. At the Enter configuration method prompt enter **manual**. The screen prompts you to enter IP information.

5 Enter the IP address, subnet mask, and gateway IP address for the Switch. The screen displays a summary of the information entered.

If using the `gettingStarted` command you will then be prompted to enter system information, change passwords, and then given the option to carry out advanced configuration.

The initial set up of your Switch is now complete and the Switch is ready for you to set up your chosen management method. See [“Methods of Managing a Switch”](#) on [page 46](#).

Connecting to the Console Port

To set up your Switch manually you can alternatively make a connection to the console port (this example describes a local connection to the console port, rather than a remote one via a modem). You can do this whilst the Switch is offline, that is, before you connect the Switch to a network, or whilst the Switch is online, that is, connected to a network.

Pre-requisites

- A workstation with terminal emulation software installed, such as Microsoft Hyperterminal. This software allows you to communicate with the Switch via the console port directly, or through a modem.

- Documentation supplied with the terminal emulation software.
- A suitable cable:
 - A standard null modem cable — if you are connecting directly to the console port, or
 - A standard modem cable — if you are connecting to the console port using a modem.



You can find pin-out diagrams for both cables in [Appendix B](#) on [page 69](#).

- You need to have the following so that you can manually set up the Switch with IP information:
 - IP address
 - subnet mask
 - default gateway

Connecting the Workstation to the Switch

- 1 Connect the workstation to the console port using a standard null modem cable as shown in [Figure 15](#).

Figure 15 Connecting a workstation to the Switch via the console port

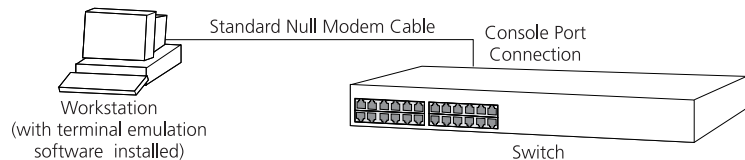

To connect the cable:

- a Attach the female connector on the cable to the male connector on the console port of the Switch.
 - b Tighten the retaining screws on the cable to prevent it from being loosened.
 - c Connect the other end of the cable to one of the serial ports (also known as a COM port) on your workstation.
- 2 Open your terminal emulation software and configure the COM port settings to which you have connected the cable. The settings should be set to match the default settings for the Switch, which are:
 - 19,200 baud
 - 8 data bits

- no parity
- 1 stop bit
- no hardware flow control

Refer to the documentation that accompanies the terminal emulation software for more information.

Setting Up the Switch with IP Information

You are now ready to manually set up the Switch with IP information using the command line interface.

- 1 The command line interface login sequence begins as soon as the Switch detects a connection to its console port.



If the login prompt does not begin immediately, press Return a few times until it starts.

- 2 At the login and password prompts, enter **admin** as your user name and press Return at the password prompt. If you have logged on correctly, the top-level menu of the command line interface is displayed as shown in the example in [Figure 16](#).

Figure 16 Example top-level command line interface menu

```
Menu options: -----3Com SuperStack 3 Switch 4xxx-----
bridge          - Administer bridge-wide parameters
feature         - Administer system features
gettingStarted  - Basic device configuration
logout          - Logout of the Command Line Interface
physicalInterface - Administer physical interfaces
protocol        - Administer protocols
security        - Administer security
system          - Administer system-level functions
trafficManagement - Administer traffic management

Type ? for help
----- (2)-----
Select menu option: █
```

- 3 At the Select menu option prompt you can either:
 - enter the **protocol ip basicConfig** command. At the `Enter configuration method` prompt enter **manual**. The screen prompts you to enter IP information.
 - or
 - enter the **gettingStarted** command. At the `Enter configuration method` prompt enter **manual**. The screen prompts you to enter IP information.

- 4 Enter the IP address, subnet mask, and gateway IP address for the Switch. The screen displays a summary of the information entered.

If using the `gettingStarted` command you will then be prompted to enter system information, change passwords, and then given the option to carry out advanced configuration.

The initial set up of your Switch is now complete and the Switch is ready for you to set up your chosen management method. See [“Methods of Managing a Switch”](#) on [page 46](#).

If you do not intend to use the command line interface via the console port to manage the Switch, you can logout, disconnect the serial cable and close the terminal emulator software.

Viewing Automatically Configured IP Information

If you allow the Switch to automatically configure its own IP information you need to discover and view the IP information before you can begin to manage the Switch. You can discover the IP information in two ways:

- Using 3Com Network Supervisor — This application will auto-discover the Switch and display the automatically allocated IP information assigned to the Switch.
- Connecting to the Console Port — Connect a workstation using a console cable to the console port of the Switch. You can then view the IP information automatically assigned to the Switch using the command line interface (CLI).

Using 3Com Network Supervisor

You can use the 3Com Network Supervisor application provided on the CD-ROM that accompanies your Switch to discover the automatically allocated IP information.

- 1 Connect your Switch to the network.
- 2 Power-up the Switch and wait for two minutes.
- 3 Launch 3Com Network Supervisor and run the Auto-discovery wizard.

3Com Network Supervisor will auto-discover the new Switch and display the IP information that has been automatically allocated to the Switch.



Most DHCP and BootP servers allow static IP addresses to be configured so that you know what IP address the Switch will be given. Refer to the documentation that accompanies your DHCP or BootP server.



If your network does not have a DHCP or BootP server, the workstation running 3Com Network Supervisor must be on the same subnet as the Switch, because Auto-IP addresses are non-routable.

Connecting to the Console Port

Alternatively, you can view the automatically configured IP information via the command line interface (CLI) through a connection to the console port. (This example describes a local connection to the console port, rather than a remote one via a modem.)

Pre-requisites

- A workstation with terminal emulation software installed, such as Microsoft Hyperterminal. This software allows you to communicate with the Switch via the console port directly, or through a modem.
- Documentation supplied with the terminal emulation software.
- A suitable cable:
 - A standard null modem cable — if you are connecting directly to the console port, or
 - A standard modem cable — if you are connecting to the console port using a modem.



You can find pin-out diagrams for both cables in [Appendix B on page 69](#).

- A Category 5 twisted pair Ethernet cable with RJ-45 connectors to connect your Switch to the network.

Connecting the Workstation to the Switch

- 1 Connect the workstation to the console port using a standard null modem cable as shown in [Figure 17](#).

Figure 17 Connecting a workstation to the Switch via the console port

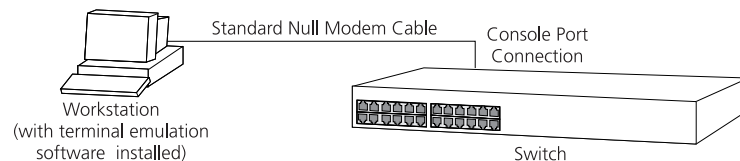

To connect the cable:

- a Attach the female connector on the cable to the male connector on the console port of the Switch.

- b Tighten the retaining screws on the cable to prevent it from being loosened.
 - c Connect the other end of the cable to one of the serial ports (also known as a COM port) on your workstation.
- 2 Open your terminal emulation software and configure the COM port settings to which you have connected the cable. The settings should be set to match the default settings for the Switch, which are:
 - 19,200 baud
 - 8 data bits
 - no parity
 - 1 stop bit
 - no hardware flow control

Refer to the documentation that accompanies the terminal emulation software for more information.

Viewing IP Information via the Console Port

You are now ready to view the automatically allocated IP information using the command line interface.

- 1 Connect your Switch to the network using an Ethernet cable. As soon as a network connection is made the Switch begins the automatic IP configuration process.



The automatic IP configuration process usually completes within one minute.



If there is no response from a DHCP server within 30 seconds, the Auto-IP configuration mechanism attempts to allocate the default IP address 169.254.100.100. If this address is not available, it then allocates an IP address in the range of 169.254.x.y (where x is in the range 1 to 254, and y is in the range 0 to 255).

- 2 The command line interface login sequence begins as soon as the Switch detects a connection to its console port.



If the login prompt does not begin immediately, press Return a few times until it starts.

- 3 At the login and password prompts, enter **admin** as your user name and press Return at the password prompt. If you have logged on correctly, the top-level menu of the command line interface is displayed as shown in the example in [Figure 18](#).

Figure 18 Example top-level command line interface menu

```

Menu options: -----3Com SuperStack 3 Switch 4xxx-----
bridge          - Administer bridge-wide parameters
feature         - Administer system features
gettingStarted  - Basic device configuration
logout         - Logout of the Command Line Interface
physicalInterface - Administer physical interfaces
protocol        - Administer protocols
security        - Administer security
system         - Administer system-level functions
trafficManagement - Administer traffic management

Type ? for help
----- (2)-----
Select menu option: █

```

- 4 At the Select menu option prompt enter the **protocol ip interface summary** command. At the Select IP interfaces prompt enter **all**. A summary of the automatically allocated IP information is displayed. Make a note of the Network IP Address.

The initial set up of your Switch is now complete and the Switch is ready for you to set up your chosen management method. See [“Methods of Managing a Switch”](#) on [page 46](#).

If you do not intend to use the command line interface via the console port to manage the Switch, you can disconnect the serial cable and close the terminal emulator software.

Methods of Managing a Switch

Once you have completed the initial set up of your Switch, you can decide how you wish to manage the Switch. You can use one of the following methods:

- Command line interface management
- Web interface management
- SNMP management

Command Line Interface Management

Each Switch has a command line interface (CLI) that allows you to manage the Switch from a workstation, either locally via a console port connection (see [Figure 19](#)), or remotely over the network (see [Figure 20](#)).

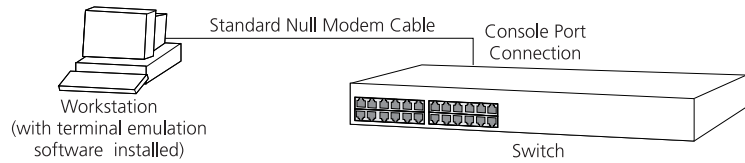
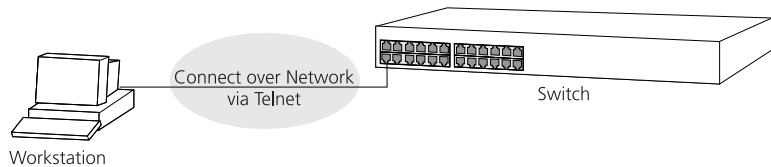
Figure 19 CLI management via the console port**Figure 20** CLI management over the network

Refer to [“Setting Up Command Line Interface Management”](#) on [page 48](#).

Web Interface Management

Each Switch has an internal set of web pages that allow you to manage the Switch using a Web browser remotely over an IP network (see [Figure 21](#)).

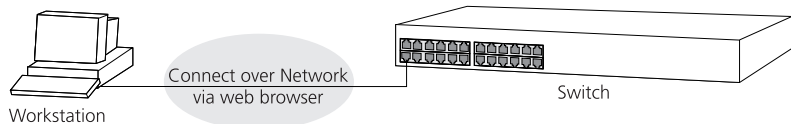
Figure 21 Web interface management over the network

Refer to [“Setting Up Web Interface Management”](#) on [page 49](#).

SNMP Management

You can manage a Switch using any network management workstation running the Simple Network Management Protocol (SNMP) as shown in [Figure 22](#). For example, you can use the 3Com Network Supervisor software that is provided on the CD-ROM that accompanies your Switch.

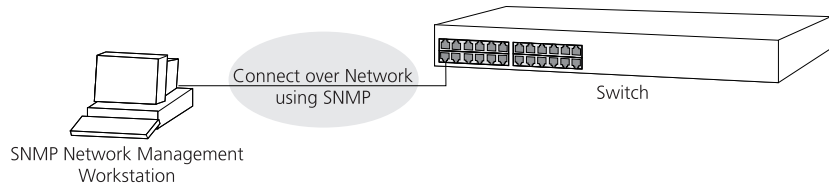
Figure 22 SNMP management over the network

Refer to [“Setting Up SNMP Management”](#) on [page 51](#).

Setting Up Command Line Interface Management

This section describes how you can set up command line interface management using a local console port connection or over the network.

CLI Management via the Console Port

To manage a Switch using the command line interface via the local console port connection:

- 1 Ensure you have connected your workstation to the console port correctly as described in [“Connecting to the Console Port”](#) on [page 40](#).
- 2 Your Switch is now ready to continue being managed and/or configured through the CLI via its console port.

CLI Management over the Network

To manage a Switch using the command line interface over a network using Telnet:

- 1 Ensure you have already set up the Switch with IP information as described in [“Setting Up Overview”](#) on [page 34](#).
- 2 Check that you have the IP protocol correctly installed on your management workstation. You can check this by trying to browse the World Wide Web. If you can browse, the IP protocol is installed.
- 3 Check you can communicate with the Switch by entering a **ping** command at the DOS prompt in the following format:

```
c:\ ping xxx.xxx.xxx.xxx
```

(where xxx.xxx.xxx.xxx is the IP address of the Switch)

If you get an error message, check that your IP information has been entered correctly and the Switch is powered up.

- 4 To open a Telnet session via the DOS prompt, enter the IP address of the Switch that you wish to manage in the following format:

```
>telnet xxx.xxx.xxx.xxx
```

(where xxx.xxx.xxx.xxx is the IP address of the Switch)



If opening a Telnet session via third party software you will need to enter the IP address in the format suitable for that software.

- 5 At the login and password prompts, enter **admin** as your user name and press Return at the password prompt (or the password of your choice if you have already modified the default passwords).



If the login prompt does not display immediately, press Return a few times until it starts.

- 6 If you have logged on correctly, the top-level menu of the command line interface for the Switch you wish to manage is displayed as shown in [Figure 16](#) on [page 42](#).

Setting Up Web Interface Management

This section describes how you can set up web interface management over the network.

Pre-requisites

- Ensure you have already set up the Switch with IP information as described in [“Setting Up Overview”](#) on [page 34](#).
- Ensure that the Switch is connected to the network using a Category 5 twisted pair Ethernet cable with RJ-45 connectors.
- A suitable Web browser.

Choosing a Browser

To display the web interface correctly, use one of the following Web browser and platform combinations:

Table 8 Supported Web Browsers and Platforms

	Windows 95	Windows 98	Windows NT 4	Windows 2000	Windows XP	Solaris 2.6
Netscape 4.76	✓	✓	✓	✓	✓	✓
Netscape 6.2	✗	✓	✓	✓	✓	✗
Internet Explorer 5.0, 5.5 and 6.0	✓	✓	✓	✓	✓	✗

For the browser to operate the web interface correctly, JavaScript and Cascading Style Sheets must be enabled on your browser. These features are enabled on a browser by default. You will only need to enable them if you have changed your browser settings.

To enable style sheets in Netscape Navigator 4.76 on Solaris 2.6, open Netscape Navigator and select *Edit > Preferences > Fonts*. Select the *Use document-specified fonts, including Dynamic Fonts* radio button. You should also set the font sizes as follows:

- Variable Width Font - Size 10.0
- Fixed Width Font - Size 12.0

This ensures that the text spacing is correct. Finally in the *Advanced* category ensure that *Enable JavaScript* and *Enable style sheets* are checked.

Web Management Over the Network

To manage a Switch using the web interface over an IP network:

- 1 Check that you have the IP protocol correctly installed on your management workstation. You can check this by trying to browse the World Wide Web. If you can browse, the IP protocol is installed.
- 2 Check you can communicate with the Switch by entering a **ping** command at the DOS prompt in the following format:

```
c:\ ping xxx.xxx.xxx.xxx
```

 (where xxx.xxx.xxx.xxx is the IP address of the Switch)

If you get an error message, check that your IP information has been entered correctly and the Switch is powered up.
- 3 Open your web browser and enter the IP address of the Switch that you wish to manage in the URL locator, for example, in the following format:

```
http://xxx.xxx.xxx.xxx
```
- 4 At the login and password prompts, enter **admin** as your user name and press Return at the password prompt (or the password of your choice if you have already modified the default passwords).
- 5 Click on the *Device View* button to display the web management options.

Setting Up SNMP Management

Any network management application running the Simple Network Management Protocol (SNMP) can manage a Switch if:

- The correct Management Information Bases (MIBs) are installed on the management workstation.
- The management workstation is connected to the Switch using a port in VLAN 1 (the Default VLAN). By default, all ports on the Switch are in VLAN 1.



You can use the 3Com Network Supervisor application that is provided on the CD-ROM that accompanies your Switch to provide SNMP management for your Switch. If you use 3Com Network Supervisor it automatically loads the correct MIBs and necessary files onto your workstation.

Pre-requisites

- Documentation supplied with the SNMP network management application software.



*To manage your Switch using an SNMP network management application, you need to specify SNMP community strings for the users defined on the Switch. You can do this using the command line interface **system management snmp community** command — refer to the command line interface section of the “Management Interface Reference Guide” for more information.*

Default Users and Passwords

If you intend to manage the Switch using the web interface or the command line interface, or to change the default passwords, you need to log in with a valid user name and password. The Switch has three default user names, and each user name has a different password and level of access. These default users are listed in [Table 9](#).



CAUTION: *To protect your Switch from unauthorized access, you must change all three default passwords as soon as possible, even if you do not intend to actively manage your Switch*

Table 9 Default Users

User Name	Default Password	Access Level
monitor	monitor	monitor — the user can view all manageable parameters, except special/security features, but cannot change any manageable parameters.
manager	manager	manager — the user can access and change the operational parameters but not special/security features
admin	(no password)	security — the user can access and change all manageable parameters



Use the admin default user name (no password) to login and carry out initial Switch setup.

Changing Default Passwords

You can change the default passwords using either:

- The **gettingStarted** command on the CLI, or
- The **security device user modify** command on the CLI, or
- The *Security > Device > User > Modify* operation on the web interface.



For more information about default users and passwords, refer to the “Management Interface Reference Guide” on the Switch CD-ROM.

4

PROBLEM SOLVING

This chapter helps you to diagnose and solve problems you may have with the operation of your Switch. There is also an explanation of IP addressing.

The topics covered are:

- [Solving Problems Indicated by LEDs](#)
- [Solving Hardware Problems](#)
- [Solving Communication Problems](#)
- [Solving Software Upgrade Problems](#)

If you experience a problem that is not listed here, it may be included in the support section of the Superstack 3 Switch Management Interface Reference Guide on the CD-ROM that accompanies your Switch.



To ensure this product provides optimum performance, high speed fans are used to provide ventilation. These fans have a high audible output.

For Technical Support information, see [Appendix D](#).

Solving Problems Indicated by LEDs

If the LEDs on the Switch indicate a problem, refer to the list of suggested solutions below.

The Power LED does not light

Check that the power cable is firmly connected to the Switch and to the supply outlet. If the connection is secure and there is still no power, you may have a faulty power cord or an internal fault. Firstly, check the power cord by:

- testing it in another device
- connecting a working power cord to the 'problem' device

then contact your supplier for advice.

On powering-up, the Power/Self Test LED lights yellow

The Switch unit has failed its Power On Self Test (POST) because of an internal problem. The fault type will be indicated on the unit LEDs. Contact your supplier for advice.

A link is connected and yet the Status LED for the port does not light

Check that:

- The Switch and the device at the other end of the link (or cable) are connected securely.
- The devices at both ends of the link are powered-up
- The quality of cable is satisfactory
- Auto-negotiation settings are the same at both ends.

Auto-negotiation problems will occur with 10BASE-T or 100BASE-T where auto-negotiation is disabled and incorrect cables are being used (cross-over or straight)

Auto-negotiation problems will occur with fiber if:

- The Receiver (RX) and Transceiver (TX) cable connectors are swapped
- Fibers are broken
- Auto-negotiation differs at either end (a link appears at the 'fixed' end and not at the auto-negotiation end)

Solving Hardware Problems

In the rare event of your Switch unit experiencing a hardware failure, refer to the list of suggested solutions below.

An expansion module is installed and the unit will not power up

Ensure that the expansion module is fully seated in the slot and the connectors are engaged so that the securing screws can be tightened.

A fan failure warning message is received

Your Switch has a fan monitoring system that will generate fan failure warning messages. Fan failure could potentially reduce the lifetime of the Switch. The monitoring system polls the fan status at periodic intervals while the unit is powered up.

Should one fan failure occur in the Switch, a warning message will be generated in the following ways:

- **RMON Email Notification** — If configured, you will receive notification of the fan failure via email, SMS (Short Message Service), or pager.
- **RMON Trap** — If configured, an RMON trap is generated and sent to the management workstation.



For further information about RMON, refer to "Chapter 7: Status Monitoring and Statistics" in the Switch Implementation Guide supplied in PDF format on the CD-ROM that accompanies the Switch.

If more than one fan fails in the Switch, a warning message will be generated by RMON Email Notification, RMON Trap and also in the following ways:

- **Command Line Interface** — An indication of a general hardware failure is provided through the Top level menu displayed when logging on to the CLI. For more detailed information about the failure select the **system summary** command.
- **Web interface** — An indication of fan failure is provided through the Device Summary table for the specific unit. In addition all Summary tables turn red to indicate the fan failure.

If a fan failure warning message is generated:

- 1 Power off the unit.
- 2 Check that the air vents are not obstructed.
- 3 Power cycle the unit. To do this, remove and reconnect the AC mains supply. If the unit has no AC main supply, remove and reconnect the DC RPS supply.
- 4 If another fan failure warning message is generated via the Command Line Interface or the Web interface, return the unit.

Unit fails, no SNMP fan failure message is received

- 1 Power cycle the unit. To do this, remove and reconnect the AC mains supply. If the unit has no AC mains supply, remove and reconnect the DC RPS supply.
- 2 Check the command line interface (**system summary** command) to determine whether a thermal shutdown has occurred.
- 3 If no, return the unit:
If yes, check that:
 - The air vents are not obstructed.
 - The ambient temperatures and environmental conditions meet those specified in [Appendix C](#).
- 4 Power cycle the unit. If a further thermal shutdown occurs, and all environmental conditions are satisfactory, return the unit to 3Com.

Error message indicating that the GBIC transceiver is invalid

The Switch has identified that the GBIC does not meet the minimum requirements for the Switch and has disabled the port. To correct this problem, completely remove the GBIC and replace it with a 3Com approved GBIC. See "[Approved GBIC Transceivers](#)" on [page 29](#)

Error message indicating that the GBIC transceiver is faulty

To correct this problem, completely remove the GBIC and then reinsert it. If the problem persists, contact 3Com Technical Support.

Solving Communication Problems

If you experience communication problems with the Switch, ensure that:

- The Switch IP address has been configured.
- If the Switch is separated from your management application by a router, ensure that the default gateway IP address within the Switch is the same as the IP address of the router.
- The Switch's IP address has been entered correctly in your network management application (for example 3Com Network Supervisor).

The following is a brief overview of IP addressing, and how to obtain a registered IP address.

IP Addressing

To be managed correctly, each device on your network (for example a Switch or Hub) must have a unique IP address. IP addresses have the format $n.n.n.n$ where n is a decimal number between 0 and 255. An example IP address is 192.168.100.8.

The IP address is split into two parts:

- The first part ('192.168.100' in the example) identifies the network on which the device resides
- The second part ('.8' in the example) identifies the device within the network

The natural subnet mask for this example is 255.255.255.0.



If your network has a connection to the external IP network, that is, you access the Internet, you must apply for a registered IP address.

How do you obtain a registered IP Address?

The IP registration system ensures that every IP address used is unique; if you do not have a registered IP address, you may be using an identical address to someone else and your network will not operate correctly.

InterNIC Registration Services is the organization responsible for supplying registered IP addresses. The following contact information is correct at time of publication:

World Wide Web site: <http://www.internic.net>

If your IP network is internal to your organization only, that is, you do not access the Internet, you may use any arbitrary IP address as long as it is not being used by another device on your network. 3Com suggests you use addresses in the series 192.160.100.X (where X is a number between 1 and 254) with a subnet mask of 255.255.255.0. These suggested IP addresses are part of a group of IP addresses that have been set aside specially for use 'in house' only.



These suggested IP addresses are part of a group of IP addresses that have been set aside specially for use 'in house' only.

Solving Software Upgrade Problems

You can upgrade the management software of the Switch by using the *System > Control > Software Upgrade* operation in the Web Interface, or the `system control softwareUpgrade` command in the command line interface. For details on these options, refer to the Management Interface Reference Guide supplied in HTML format on the CD-ROM that accompanies your Switch.

If you have problems with your software upgrade, refer to the Problem Solving section in the Management Interface Reference Guide.

A

SAFETY INFORMATION

You must read the following safety information before carrying out any installation or removal of components, or any maintenance procedures on the Switch 4900, 4900 SX, 4924, or 4950.



WARNING: Warnings contain directions that you must follow for your personal safety. Follow all directions carefully.

You must read the following safety information carefully before you install or remove the unit.



AVERTISSEMENT: Les avertissements présentent des consignes que vous devez respecter pour garantir votre sécurité personnelle. Vous devez respecter attentivement toutes les consignes.

Nous vous demandons de lire attentivement les consignes suivantes de sécurité avant d'installer ou de retirer l'appareil.



VORSICHT: Vorsicht enthalten Anweisungen, die Sie zu Ihrer eigenen Sicherheit befolgen müssen. Alle Anweisungen sind sorgfältig zu befolgen.

Sie müssen die folgenden Sicherheitsinformationen' sorgfältig durchlesen, bevor Sie das Gerät installieren oder ausbauen.

Important Safety Information



WARNING: Installation and removal of the unit must be carried out by qualified personnel only.



WARNING: If installing the Switch in a stack with SuperStack 3 units that are narrower than the Switch, the Switch unit must be installed below the narrower units.



WARNING: The unit must be earthed (grounded).



WARNING: Connect the unit to an earthed power supply to ensure compliance with safety standards.



WARNING: Power Cord Set:
This must be approved for the country where it is used:

U.S.A. and
Canada

- The cord set must be UL-approved and CSA certified.
- The minimum specification for the flexible cord is:
No. 18 AWG
Type SV or SJ
3-conductor
- The cord set must have a rated current capacity of at least 10A.
- The attachment plug must be an earth-grounding type with a NEMA 5-15P (15A, 125V) or NEMA 6-15P (15A, 250V) configuration.

United
Kingdom only

- The supply plug must comply with BS1363 (3-pin 13 amp) and be fitted with a 5A fuse which complies with BS1362.
- The mains cord must be <HAR> or <BASEC> marked and be of type H03VVF3GO.75 (minimum).

Europe only:

- The supply plug must comply with CEE 7/7 ("SCHUKO").
- The mains cord must be <HAR> or <BASEC> marked and be of type H03VVF3GO.75 (minimum).

Denmark

- The supply plug must comply with section 107-2-D1, standard DK2-1a or DK2-5a.

Switzerland

- The supply plug must comply with SEV/ASE 1011.



WARNING: The appliance coupler (the connector to the unit and not the wall plug) must have a configuration for mating with an EN60320/IEC320 appliance inlet.



WARNING: The socket outlet must be near to the unit and easily accessible. You can only remove power from the unit by disconnecting the power cord from the outlet.



WARNING: This unit operates under SELV (Safety Extra Low Voltage) conditions according to IEC 60950. The conditions are only maintained if the equipment to which it is connected also operates under SELV conditions.



WARNING: France and Peru only:
This unit cannot be powered from IT⁺ supplies. If your supplies are of IT type, this unit must be powered by 230V (2P+T) via an isolation transformer ratio 1:1, with the secondary connection point labelled Neutral, connected directly to earth (ground).
*Impédance à la terre.



WARNING: U.K. only:
If connecting a modem to the console port of the Switch, only use a modem which is suitable for connection to the telecommunications system.



WARNING: RJ-45 Ports. These are shielded RJ-45 data sockets. They cannot be used as standard traditional telephone sockets, or to connect the unit to a traditional PBX or public telephone network. Only connect RJ-45 data connectors, network telephony systems, or network telephones to these sockets.

Either shielded or unshielded data cables with shielded or unshielded jacks can be connected to these data sockets.



WARNING: The switch should only be used in a rack if it is mounted on runners, a shelf, or a tray to support the weight. The rack mount kits alone are not sufficient to support the weight of the switch. The rack mount kits must not be used to suspend the switch from under a table or desk, or attach it to a wall.



WARNING: If you are connecting the Switch to a Type 3 Power Module, read the Safety Information section in the Type 3 Power Module User Guide.



WARNING: When an Expansion Module is not installed ensure the blanking panel is fitted by tightening all screws with a suitable tool.



WARNING: *Fiber Optic ports - Optical Safety*



Never look at the transmit laser while it is powered-up. Never look directly at the fiber ports and fiber cable ends when they are powered-up.



WARNING: *Use of controls or adjustments of performance or procedures other than those specified herein may result in hazardous laser emissions.*



WARNING: *The Switch must only be fitted with 3Com approved GBIC transceivers, as listed below.*

- 3CGBIC91 GBIC (SX)
- 3CGBIC92 GBIC (LX)
- 3CGBIC97 GBIC (LH70)

L'information de Sécurité Importante



AVERTISSEMENT: L'installation et la dépose de ce groupe doivent être confiés à un personnel qualifié.



AVERTISSEMENT: Si vous entassez l'unité Switch avec les unités SuperStack 3 Hub, l'unité Switch doit être installée en dessous des unités Hub plus étroites.



AVERTISSEMENT: Vous devez mettre l'appareil à la terre (à la masse) ce groupe.



AVERTISSEMENT: Brancher l'unité à une source de courant mise à la terre pour assurer la conformité aux normes de sécurité.



AVERTISSEMENT: Cordon électrique:
Il doit être agréé ans le pays d'utilisation:

- | | |
|----------------------|--|
| Etats-Unis et Canada | <ul style="list-style-type: none"> ■ Le cordon doit avoir reçu l'homologation des UL et un certificat de la CSA ■ Le cordon souple doit respecter, à titre minimum, les spécifications suivantes : <ul style="list-style-type: none"> ■ calibre 18 AWG ■ type SV ou SJ ■ à 3 conducteurs ■ Le cordon doit être en mesure d'acheminer un courant nominal d'au moins 10 A ■ La prise femelle de branchement doit être du type à mise à la terre (mise à la masse) et respecter la configuration NEMA 5-15P (15 A, 125 V) ou NEMA 6-15P (15 A, 250 V) |
| Danemark | <ul style="list-style-type: none"> ■ La prise mâle d'alimentation doit respecter la section 107-2 D1 de la norme DK2 1a ou DK2 5a |
| Europe | <ul style="list-style-type: none"> ■ La prise secteur doit être conforme aux normes CEE 7/7 ("SCHKO") ■ LE cordon secteur doit porter la mention <HAR> ou <BASEC> et doit être de type HO3VVH3GO.75 (minimum). |
| Suisse | <ul style="list-style-type: none"> ■ La prise mâle d'alimentation doit respecter la norme SEV/ASE 1011 |



AVERTISSEMENT: Le coupleur d'appareil (le connecteur du groupe et non pas la prise murale) doit respecter une configuration qui permet un branchement sur une entrée d'appareil EN60320/CEI 320.



AVERTISSEMENT: La prise secteur doit se trouver à proximité de l'appareil et son accès doit être facile. Vous ne pouvez mettre l'appareil hors circuit qu'en débranchant son cordon électrique au niveau de cette prise.



AVERTISSEMENT: L'appareil fonctionne à une tension extrêmement basse de sécurité qui est conforme à la norme CEI 60950. Ces conditions ne sont maintenues que si l'équipement auquel il est raccordé fonctionne dans les mêmes conditions.



AVERTISSEMENT: France et Pérou uniquement:
Ce groupe ne peut pas être alimenté par un dispositif à impédance à la terre. Si vos alimentations sont du type impédance à la terre, ce groupe doit être alimenté par une tension de 230 V (2 P+T) par le biais d'un transformateur d'isolement à rapport 1:1, avec un point secondaire de connexion portant l'appellation Neutre et avec raccordement direct à la terre (masse).



AVERTISSEMENT: Points d'accès RJ-45. Ceux-ci sont protégés par des prises de données. Ils ne peuvent pas être utilisés comme prises de téléphone conventionnelles standard, ni pour la connection de l'unité à un réseau téléphonique central privé ou public. Raccorder seulement connecteurs de données RJ-45, systèmes de réseaux de téléphonie ou téléphones de réseaux à ces prises.

Il est possible de raccorder des câbles protégés ou non protégés avec des jacks protégés ou non protégés à ces prises de données.



AVERTISSEMENT: Le commutateur doit être utilisé en rack uniquement s'il est monté sur des rails à glissières, une étagère ou un plateau pour supporter son poids. Les kits de montage en rack ne suffisent pas à eux seuls pour supporter le poids du commutateur.



AVERTISSEMENTS: Si vous connectez le commutateur Switch à un module d'alimentation de Type 3, consultez les informations de sécurité qui se trouvent dans le guide de l'utilisateur du module d'alimentation de type 3.



AVERTISSEMENTS: Si le module d'expansion n'est pas installé, veuillez bien installer la plaque d'obturation et serrez toutes les vis à l'aide d'un outil approprié.



AVERTISSEMENT: Ports pour fibres optiques – sécurité sur le plan optique



Ne regardez jamais le laser tant qu'il est sous tension. Ne regardez jamais directement le port à fibres optiques et les embouts de câbles à fibres optiques tant qu'ils sont sous tension.



AVERTISSEMENT: L'utilisation de contrôles, de réglages de performances ou de procédures autres que ceux qui sont spécifiés au sein du présent document risquent d'entraîner l'exposition à des rayonnements laser dangereux.



AVERTISSEMENT: Le commutateur ne doit être utilisé qu'avec des modules Transceiver GBIC approuvés par 3Com.

- 3CGBIC91 GBIC (SX)
- 3CGBIC92 GBIC (LX)
- 3CGBIC97 GBIC (LH70)

Wichtige Sicherheitsinformationen



VORSICHT: Die Installation und der Ausbau des Geräts darf nur durch Fachpersonal erfolgen.



VORSICHT: Wenn die Switch Einheit in einer Stapel mit anderen SuperStack 3 Hub Einheiten eingebaut werden soll, muß die Switch Einheit unter die schmalere Hub Einheiten eingebaut werden.



VORSICHT: Das Gerät muß geerdet sein.



VORSICHT: Das Gerät muß an eine geerdete Steckdose angeschlossen werden, die europäischen Sicherheitsnormen erfüllt.



VORSICHT: Der Anschlußkabelsatz muß mit den Bestimmungen des Landes übereinstimmen, in dem er verwendet werden soll.



VORSICHT: Der Gerätestecker (der Anschluß an das Gerät, nicht der Wandsteckdosenstecker) muß eine passende Konfiguration für einen Geräteeingang gemäß EN60320/IEC320 haben.



VORSICHT: Die Netzsteckdose muß in der Nähe des Geräts und leicht zugänglich sein. Die Stromversorgung des Geräts kann nur durch Herausziehen des Gerätenetzkabels aus der Netzsteckdose unterbrochen werden.



VORSICHT: Europe

- Das Netzkabel muß vom Typ HO3VVF3GO.75 (Mindestanforderung) sein und die Aufschrift <HAR> oder <BASEC> tragen.
- Der Netzstecker muß die Norm CEE 7/7 erfüllen ("SCHUKO").



VORSICHT: Der Betrieb dieses Geräts erfolgt unter den SELV-Bedingungen (Sicherheitskleinstspannung) gemäß IEC 60950. Diese Bedingungen sind nur gegeben, wenn auch die an das Gerät angeschlossenen Geräte unter SELV-Bedingungen betrieben werden.



VORSICHT: RJ-45-Porte. Diese Ports sind geschützte Datensteckdosen. Sie dürfen weder wie normale traditionelle Telefonsteckdosen noch für die Verbindung der Einheit mit einem traditionellem privatem oder öffentlichem Telefonnetzwerk gebraucht werden. Nur RJ-45-Datenanschlüsse, Telefonnetzsysteme oder Netztelefone an diese Steckdosen anschließen.

Entweder geschützte oder ungeschützte Buchsen dürfen an diese Datensteckdosen angeschlossen werden.



VORSICHT: Der Switch darf nur dann in einem Einschub montiert werden, wenn dieser zur Tragkraftverstärkung auf einer Laufschiene, in einem Regal oder einem Träger montiert ist. Der Einschubmontagesatz alleine reicht nicht aus, um das Gewicht des Switch zu tragen.



VORSICHT: Ist kein Erweiterungsmodul installiert, überprüfen Sie bitte den Sitz der Stanzplatte, indem Sie alle Schrauben mit einem geeigneten Werkzeug anziehen.



VORSICHT: Bevor Sie den Schalter an das Stromversorgungsmodul Typ 3 anschließen, lesen Sie bitte die Sicherheitshinweise in der Bedienungsanleitung für das Stromversorgungsmodul Typ 3.



VORSICHT: Faseroptikanschlüsse – Optische Sicherheit



Niemals ein Übertragungslaser betrachten, während dieses eingeschaltet ist. Niemals direkt auf die Faseranschlüsse und auf die Faserkabelenden schauen, während diese eingeschaltet sind.



VORSICHT: Die Verwendung von Steuerelementen oder die Anpassung von Leistungen und Verfahren in anderer als der hierin genannten Weise kann zu gefährlichen Laseremissionen führen.



VORSICHT: Der Switch sollte nur mit von der Firma 3Com zugelassenen GBIC Transceivermodulen, wie unten aufgeführt, bestückt werden.

- 3CGBIC91 GBIC (SX)
- 3CGBIC92 GBIC (LX)
- 3CGBIC97 GBIC (LH70)

B

PIN-OUTS

Null Modem Cable

9-pin to RS-232 25-pin

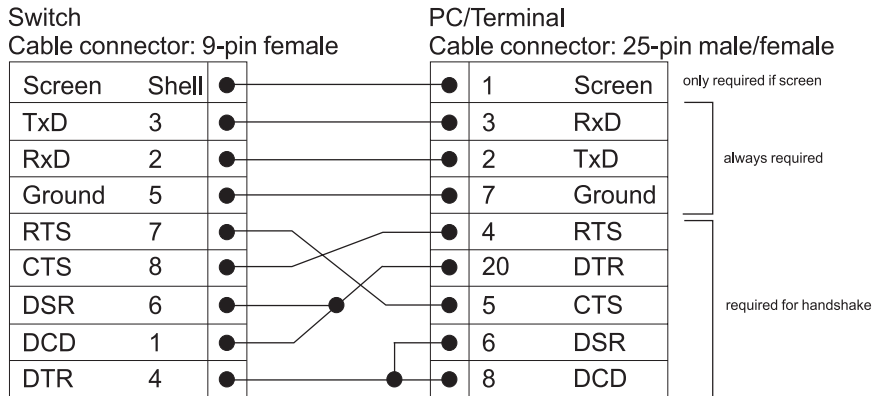

PC-AT Serial Cable

9-pin to 9-pin

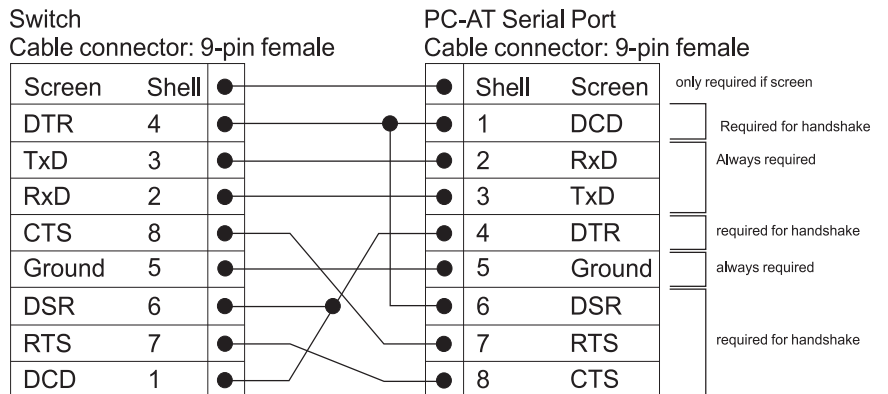

Modem Cable

9-pin to RS-232 25-pin

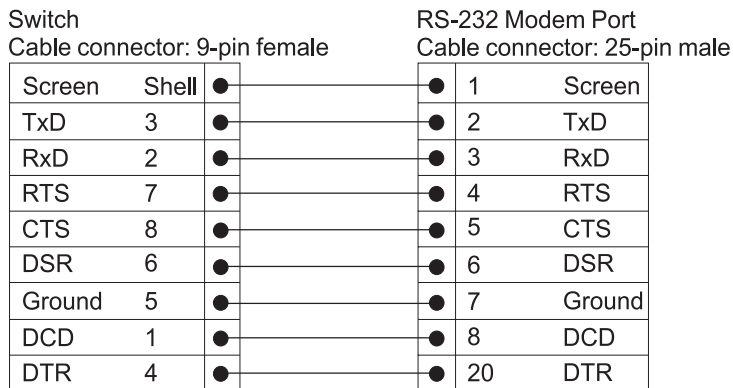

RJ-45 Pin Assignments

Pin assignments are identical for 10/100BASE-T and 1000BASE-T RJ-45 connectors.

Table 10 Pin assignments

Pin Number	10/100BASE-T	1000BASE-T
<i>Ports configured as MDI</i>		
1	Transmit Data +	Bidirectional Data A+
2	Transmit Data -	Bidirectional Data A-
3	Receive Data +	Bidirectional Data B+
4	Not assigned	Bidirectional Data C+
5	Not assigned	Bidirectional Data C-
6	Receive Data -	Bidirectional Data B-
7	Not assigned	Bidirectional Data D+
8	Not assigned	Bidirectional Data D-

Table 11 Pin assignments

Pin Number	10/100BASE-T	1000BASE-T
<i>Ports configured as MDIX</i>		
1	Receive Data +	Bidirectional Data B+
2	Receive Data -	Bidirectional Data B-
3	Transmit Data +	Bidirectional Data A+
4	Not assigned	Bidirectional Data D+
5	Not assigned	Bidirectional Data D-
6	Transmit Data -	Bidirectional Data A-
7	Not assigned	Bidirectional Data C+
8	Not assigned	Bidirectional Data C-



TECHNICAL SPECIFICATIONS

The technical specifications for the Switches in the Switch 4900 Series are the same unless otherwise stated.

Physical Dimensions	Switch 4900: Switch Height: 65.8 mm (2.59 in.) x Width: 440 mm (17.3 in.) x Depth: 363.4 mm (14.30 in.) (not including bulge). Weight: 6.3 Kg (13.88 lbs) Switch 4900 SX: Height: 65.8 mm (2.59 in.) x Width: 440 mm (17.3 in.) x Depth: 363.4 mm (14.30 in.) (not including bulge). Weight: 6.0 Kg (13.22 lbs) Switch 4924: Height: 65.8 mm (2.59 in.) x Width: 440 mm (17.3 in.) x Depth: 413 mm (16.27 in.) (not including bulge). Weight: 6.4 Kg (14.10 lbs) Switch 4950: Height: 65.8 mm (2.59 in.) x Width: 440 mm (17.3 in.) x Depth: 413 mm (16.27 in.) (not including bulge). Weight: 6.91 Kg (15.23 lbs)
Environmental Requirements	
Operating Temperature	0 ° to 40 °C (32 ° to 104 °F)
Storage Temperature	-10 ° to +70 °C (14 ° to 158 °F)
Operating Humidity	10–95% relative humidity, non-condensing
Standards	EN60068 to 3Com schedule (Package testing: paras 2.1, 2.2, 2.30, and 2.32. Operational testing: paras 2.1, 2.2, 2.30 and 2.13).
Safety	
Agency Certifications	UL 1950 / UL60950, EN60950, CSA 22.2 No. 950 / CSA 22.2 No. 60950, IEC 60950, IEC 825-1 (4900 SX and 4950 only), EN 60825-1 (4900 SX and 4950 only)
EMC	
Emissions	CISPR 22 Class A, EN55022 Class A, FCC Part 15 Subpart B Class A, ICES-003 Class A, VCCI Class A, AS/NZS 3548 Class A, CNS 13438 Class A, EN61000-3-2
Immunity	EN 55024
Power Consumption	Switch 4900: 308 watts maximum Switch 4900 SX: 162 watts maximum Switch 4924: 254 watts maximum Switch 4950: 200 watts maximum

Heat Dissipation	Switch 4900: 1050 BTU/hour maximum Switch 4900 SX: 560 BTU/hour maximum Switch 4924: 870 BTU/hour maximum Switch 4950: 685 BTU/hour maximum	
Power Supply		
AC Line Frequency	50/60 Hz	
Input Voltage Options	90–240 VAC	
Current Rating	Switch 4900: 4 A (amps) (maximum) Switch 4900 SX: 3 A (amps) (maximum) Switch 4924 and 4950: 4.5 A (amps) (maximum)	
Standards Supported	SNMP: SNMP protocol (RFC 1157) MIB-II (RFC 1213) Bridge MIB (RFC 1493) RMON MIB II (RFC 2021) Remote Monitoring MIB (RFC 1757) MAU MIB (RFC 2239)	Terminal Emulation: Telnet (RFC 854) Protocols Used for Administration: UDP (RFC 768) IP (RFC 791) ICMP (RFC 792) TCP (RFC 793) ARP (RFC 826) TFTP (RFC 783) DHCP (RFC 2131, RFC 2132, RFC 1534) BOOTP (RFC 951, RFC 1497) IGMP (RFC 1112 & 2236) RADIUS (RFC 2865, 1321, & 2869) RMON: (RFC 2819)

D

TECHNICAL SUPPORT

3Com provides easy access to technical support information through a variety of services. This appendix describes these services.

Information contained in this appendix is correct at time of publication. For the most recent information, 3Com recommends that you access the 3Com Corporation World Wide Web site.

Online Technical Services

3Com offers worldwide product support 24 hours a day, 7 days a week, through the following online systems:

- World Wide Web site
- 3Com Knowledgebase Web Services
- 3Com FTP site

World Wide Web Site

To access the latest networking information on the 3Com Corporation World Wide Web site, enter this URL into your Internet browser:

<http://www.3com.com/>

This service provides access to online support information such as technical documentation and software, as well as support options that range from technical education to maintenance and professional services.

3Com Knowledgebase Web Services

The 3Com Knowledgebase is a database of technical information to help you install, upgrade, configure, or support 3Com products. The Knowledgebase is updated daily with technical information discovered by 3Com technical support engineers. This complimentary service, which is available 24 hours a day, 7 days a week to 3Com customers and partners, is located on the 3Com Corporation World Wide Web site at:

<http://knowledgebase.3com.com>

3Com FTP Site Download drivers, patches, software, and MIBs across the Internet from the 3Com public FTP site. This service is available 24 hours a day, 7 days a week.

To connect to the 3Com FTP site, enter the following information into your FTP client:

- Hostname: **ftp.3com.com**
- Username: **anonymous**
- Password: **<your Internet e-mail address>**



You do not need a user name and password with Web browser software such as Netscape Navigator and Internet Explorer.

Support from Your Network Supplier

If you require additional assistance, contact your network supplier. Many suppliers are authorized 3Com service partners who are qualified to provide a variety of services, including network planning, installation, hardware maintenance, application training, and support services.

When you contact your network supplier for assistance, have the following information ready:

- Product model name, part number, and serial number
- A list of system hardware and software, including revision levels
- Diagnostic error messages
- Details about recent configuration changes, if applicable

If you are unable to contact your network supplier, see the following section on how to contact 3Com.

Support from 3Com If you are unable to obtain assistance from the 3Com online technical resources or from your network supplier, 3Com offers email and telephone technical support services. To find out more about your support options, email or call the 3Com technical support services at the location nearest you.

Email Support Some 3Com regions offer an email support service. To access this service for your region, use the appropriate URL or email address from the list below.

Asia, Pacific Rim

From this region, email:

`apr_technical_support@3com.com`

Europe, Middle East and Africa

From this region, enter the URL:

`http://emea.3com.com/support/email.html`

Latin America

Spanish speakers, enter the URL:

`http://lat.3com.com/lat/support/form.html`

Portuguese speakers, enter the URL:

`http://lat.3com.com/br/support/form.html`

English speakers, email:

`lat_support_anc@3com.com`

Telephone Support When you contact 3Com for assistance, have the following information ready:

- Product model name, part number, and serial number
- A list of system hardware and software, including revision levels
- Diagnostic error messages
- Details about recent configuration changes, if applicable

Here is a list of worldwide technical telephone support numbers. These numbers are correct at the time of publication. Refer to the 3Com Web site for updated information.

Country	Telephone Number	Country	Telephone Number
Asia, Pacific Rim			
Australia	1 800 678 515	Philippines	1235 61 266 2602 or +61 2 9937 5076
Hong Kong	800 933 486	P.R. of China	10800 61 00137 or 021 6350 1590 or 00800 0638 3266
India	+61 2 9424 5179 or 000800 650 1111		Singapore
Indonesia	001 803 61009	S. Korea	00798 611 2230 or 02 3455 6455
Japan	00531 616 439 or 03 5977 7991	Taiwan	00801 611 261
Malaysia	1800 801 777	Thailand	001 800 611 2000
New Zealand	0800 446 398		
Pakistan	+61 2 9937 5083		
Europe, Middle East and Africa			
From anywhere in these regions, call:	+44 (0)1442 435529		
From the following countries, you may use the numbers shown:			
Austria	01 7956 7124	Luxembourg	800 29880
Belgium (Flemish)	070 700 000	Netherlands	0900 777 7737
Belgium (French)	070 700 770	Norway	815 33 047
Denmark	7010 7289	Poland	00800 441 1357
Finland	01080 2783	Portugal	707 200 123
France	0825 809 622	South Africa	0800 991196
Germany	01805 404 747	Spain	9 021 60455
Hungary	06800 14466	Sweden	07711 14453
Ireland	1800 509359	Switzerland	08488 50112
Israel	1800 943 2632	U.K.	0870 241 3901
Italy	199 161346		
Latin America			
Antigua	1 800 988 2112	Guatemala	AT&T +800 998 2112
Argentina	0 810 444 3COM	Haiti	57 1 657 0888
Aruba	1 800 998 2112	Honduras	AT&T +800 998 2112
Bahamas	1 800 998 2112	Jamiaca	1 800 998 2112
Barbados	1 800 998 2112	Martinique	571 657 0888
Belize	52 5 201 0010	Mexico	01 800 849CARE
Bermuda	1 800 998 2112	Nicaragua	AT&T +800 998 2112
Bonaire	1 800 998 2112	Panama	AT&T +800 998 2112
Brazil	0800 13 3COM	Paraguay	54 11 4894 1888
Cayman	1 800 998 2112	Peru	AT&T +800 998 2112
Chile	AT&T +800 998 2112	Puerto Rico	1 800 998 2112
Colombia	AT&T +800 998 2112	Salvador	AT&T +800 998 2112
Costa Rica	AT&T +800 998 2112	Trinidad and Tobago	1 800 998 2112
Curacao	1 800 998 2112	Uruguay	AT&T +800 998 2112
Ecuador	AT&T +800 998 2112	Venezuela	AT&T +800 998 2112
Dominican Republic	AT&T +800 998 2112	Virgin Islands	57 1 657 0888
North America	1 800 876 3266		

Returning Products for Repair

Before you send a product directly to 3Com for repair, you must first obtain an authorization number. Products sent to 3Com without authorization numbers will be returned to the sender unopened, at the sender's expense.

You can obtain an authorization number (called an RMA) by entering the following URL into your Internet browser:

http://www.3com.com/support/en_US/repair

Alternatively, you can obtain an RMA by calling or faxing one of the following numbers:

Country	Telephone Number	Country	Telephone Number
Asia, Pacific Rim			
From anywhere in this region call:	+ 65 543 6500 phone + 65 543 6348 fax		
Europe, Middle East and Africa			
From anywhere in these regions, call:	+44 (0)1442 435529		
From the following countries, you may use the numbers shown:			
Austria	01 7956 7124	Luxembourg	800 29880
Belgium (Flemish)	070 700 000	Netherlands	0900 777 7737
Belgium (French)	070 700 770	Norway	815 33 047
Denmark	7010 7289	Poland	00800 441 1357
Finland	01080 2783	Portugal	707 200 123
France	0825 809 622	South Africa	0800 991196
Germany	01805 404 747	Spain	9 021 60455
Hungary	06800 14466	Sweden	07711 14453
Ireland	1800 509359	Switzerland	08488 50112
Israel	1800 943 2632	U.K.	0870 241 3901
Italy	199 161346		

Country	Telephone Number	Country	Telephone Number
Latin America			
Antigua	1 800 988 2112	Guatemala	AT&T +800 998 2112
Argentina	0 810 444 3COM	Haiti	57 1 657 0888
Aruba	1 800 998 2112	Honduras	AT&T +800 998 2112
Bahamas	1 800 998 2112	Jamaica	1 800 998 2112
Barbados	1 800 998 2112	Martinique	571 657 0888
Belize	52 5 201 0010	Mexico	01 800 849CARE
Bermuda	1 800 998 2112	Nicaragua	AT&T +800 998 2112
Bonaire	1 800 998 2112	Panama	AT&T +800 998 2112
Brazil	0800 13 3COM	Paraguay	54 11 4894 1888
Cayman	1 800 998 2112	Peru	AT&T +800 998 2112
Chile	AT&T +800 998 2112	Puerto Rico	1 800 998 2112
Colombia	AT&T +800 998 2112	Salvador	AT&T +800 998 2112
Costa Rica	AT&T +800 998 2112	Trinidad and Tobago	1 800 998 2112
Curacao	1 800 998 2112	Uruguay	AT&T +800 998 2112
Ecuador	AT&T +800 998 2112	Venezuela	AT&T +800 998 2112
Dominican Republic	AT&T +800 998 2112	Virgin Islands	57 1 657 0888
North America			
	1 800 876 3266 phone		
From U.S.A and Canada call:	1 508 323 6061 fax (not toll free)		

INDEX

Numbers

3C number 19
3Com Knowledgebase Web Services 75
3Com URL 75

A

access levels of default users 51
approved GBIC transceivers 29
automatic setup 43
 3Com Network Supervisor 43
 console port 44

C

cable
 10/100/1000BASE-T 27
 fiber 28
 pin-outs 69
CD-ROM 9
command line interface
 management 46
conventions
 notice icons, About This Guide 8
 text, About This Guide 8
cross-over configuration 27

D

default
 settings 20
 users 51

E

Ethernet address of the Switch 19

F

factory defaults 20

G

GBIC
 ports 16

H

hardware features 13

I

installing the Switch 21
 prerequisites 23
interconnect cable 25
IP addressing
 registered 58
IP configuration 35

L

LEDs 17
logging in as a default user 51

M

MAC address of the Switch 19
management
 methods 46
 preparing for 36
 setting up 33, 34
manual setup
 console port 40
 front panel port 37
MDI configuration 27
MDIX configuration 27
MIBs 76

N

network supplier support 76

O

online technical services 75

P

passwords
 of default users 51
pin assignments
 modem cable 70
 null modem cable 69
 RJ-45 70
 serial cable 69
pin-outs 69
ports
 10/100/1000BASE-T 16
 1000BASE-SX 16
 GBIC 16
power socket 19
powering-up a Switch 26
problem solving 53
 communication problems 57
 hardware problems 55
 IP addressing 55
 LEDs 54
product name 19

R

rack mounting a Switch 23
Redundant Power System. *See* RPS
returning products for repair 79
RPS 19
 socket 19

S

safety information
 English 60
 French 63
 German 66
serial number of the Switch 19
Simple Network Management Protocol. *See* SNMP
SNMP 51
SNMP management 47
 setting up 51
socket
 power 19
 RPS 19
specifications, system 73
straight-through configuration 27
Switch
 3C number 19
 automatic setup 43
 dimensions 73
 Ethernet address 19
 features 13

 installation 21, 23
 interconnecting 24
 MAC address 19
 power socket 19
 powering-up 26
 product name 19
 rack mounting 23
 RPS socket 19
 serial number 19
 size 73
 unit information label 19
 weight 73
 XRN Distributed Fabric 24
system specifications 73

T

technical support
 3Com Knowledgebase Web Services 75
 3Com URL 75
 network suppliers 76
 product repair 79
troubleshooting 53

U

unit information label 19
URL 75

W

web interface management 47
 setting up 49
World Wide Web (WWW) 75

X

XRN Interconnect Module Kit 25

REGULATORY NOTICES

FCC STATEMENT

This equipment has been tested and found to comply with the limits for a Class A digital device, pursuant to part 15 of the FCC rules. These limits are designed to provide reasonable protection against harmful interference when the equipment is operated in a commercial environment. This equipment generates, uses and can radiate radio frequency energy and, if not installed and used in accordance with the instructions, may cause harmful interference to radio communications. Operation of this equipment in a residential area is likely to cause harmful interference to radio communications, in which case the user will be required to correct the interference at their own expense.

INFORMATION TO THE USER

If this equipment does cause interference to radio or television reception, which can be determined by turning the equipment off and on, the user is encouraged to try to correct the interference by one or more of the following measures:

- Reorient the receiving antenna.
- Relocate the equipment with respect to the receiver.
- Move the equipment away from the receiver.
- Plug the equipment into a different outlet so that equipment and receiver are on different branch circuits.

If necessary, the user should consult the dealer or an experienced radio/television technician for additional suggestions. The user may find the following booklet prepared by the Federal Communications Commission helpful:

How to Identify and Resolve Radio-TV Interference Problems

This booklet is available from the U.S. Government Printing Office, Washington, DC 20402, Stock No. 004-000-00345-4.

In order to meet FCC emissions limits, this equipment must be used only with cables which comply with IEEE 802.3.

CSA STATEMENT

This Class A digital apparatus meets all requirements of the Canadian Interference-Causing Equipment Regulations.

Cet appareil numérique de la classe A respecte toutes les exigences du Règlement sur le matériel brouilleur du Canada.

CE STATEMENTS (EUROPE)

This product complies with the European Low Voltage Directive 73/23/EEC and EMC Directive 89/336/EEC as amended by European Directive 93/68/EEC.

Warning: This is a class A product. In a domestic environment this product may cause radio interference in which case the user may be required to take adequate measures.

You must only insert a 3Com approved GBIC transceiver into the Switch. These are listed in the "Approved GBIC Transceivers" section of the Getting Started Guide.

VCCI STATEMENT

この装置は、情報処理装置等電波障害自主規制協議会（VCCI）の基準に基づくクラスA情報技術装置です。この装置を家庭環境で使用すると電波妨害を引き起こすことがあります。この場合には使用者が適切な対策を講ずるよう要求されることがあります。

BSMI STATEMENT

警告使用者：這是甲類的資訊產品，在居住的環境中使用時，可能會造成射頻干擾，在這種情況下，使用者會被要求採取某些適當的對策。